

CUSTOMER	
SHIP NO.	
BUILDER	

Mark	Engine Type	Turbo Charger Type	X : Apply	
			Tier 2	Tier 3 (LPSCR)
01	6UEC33LSE-C2	MET33MB×1	×	
		MET33MB×1 with jet assist	×	
		MET33MB/-EGB×1	×	
		MET33MB/-EGB×1 with jet assist	×	
		MET37MB×1	×	
		MET37MB×1 with jet assist	×	
		MET37MB/-EGB×1	×	
		MET37MB/-EGB×1 with jet assist	×	
02	6UEC33LSE-C2-LPSCR	MET33MB×1		
		MET33MB×1 with jet assist		
		MET33MB-EGB×1		×
		MET33MB-EGB×1 with jet assist		×
		MET37MB×1		
		MET37MB×1 with jet assist		
		MET37MB-EGB×1		×
		MET37MB-EGB×1 with jet assist		×

電子ガバナ用
For Electric Governor Type
機械式注油用
For Mechanical Lubricator Type

DESTINATION	SERIAL NO.	MODEL	6UEC33LSE/-LPSCR	
	ORDER NO.	<p style="text-align: center;">諸管線図集 PIPING DIAGRAM</p>		
	ENGINEERING DEPARTMENT			
	APPROVED K.Edo			
	CHECKED K.Imanaka S.lima			
	DRAWN	DATE	DRAWING NO.	REV.
	Feb.8, 2017			
	SHEETS	SHEETS		
Total	21 (with cover)	U7-0E119	C	











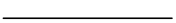

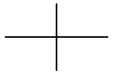

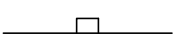

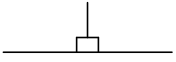
諸管線図名称

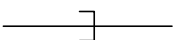
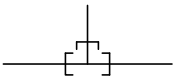

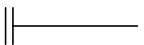
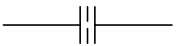











Name of piping diagram

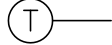
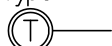

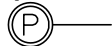



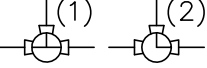

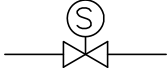
U7-0E119/A		Starting air 始動空気管線図
" "		Fuel oil 燃料油管線図
" "		Fuel oil (steam or thermal oil) 燃料油加熱管線図 (蒸気または熱媒油)
" "		Lubricating oil 潤滑油管線図
" "		Piston cooling oil ピストン冷却油管線図
" "		Actuator oil for exhaust valve 排気弁駆動油管線図
" "		Cylinder lubricating oil シリンダ注油管線図
" "		Turbocharger lubricating oil 過給機潤滑油管線図
" "		Cylinder cooling water シリンダ冷却水管線図
" "		Air cooler cooling water 空気冷却器冷却水管線図
" "		Stuffing box drain and piston under drain ピストン棒パッキン箱ドレン管及び シリンダ下部ドレン管線図
" "		Scavenging air trunk drain 掃気トランクドレン管線図
" "		Turbocharger and air cooler washing water, and exhaust gas system 過給機空気冷却器洗浄水管及び排気ガス線図
" "		Fire extinguishing 掃気室火災消火装置管線図

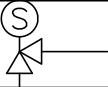

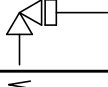
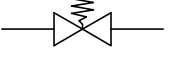
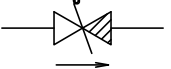
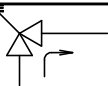
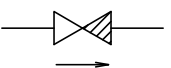
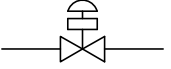

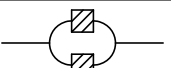

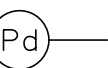
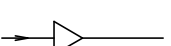
SYMBOLS FOR MAIN ENGINE PIPING DIAGRAM

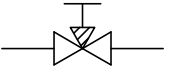
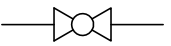
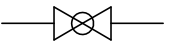
主 機 関 諸 管 線 図 記 号

SYMBOLS 記 号	NAME	名 称	REMARKS 備 考
	Nominal inner diameter	称 呼 口 径	
	Crossing pipes, connected	連 結 管	
	Crossing Pipes, not connected	不 連 結 管	
	To bilge	ビ ル ジ ヘ	
	Boss	ボ ス	
	Boss and plug	プ ラ グ 付 ボ ス	
	Joint, bossed	ボ ス 継 手	
	Joint, flanged	フ ラ ン ジ 継 手	
	Joint, screwed	ね じ 継 手	
	Tee joint, screwed	T 形 ね じ 継 手	
	Spectacle flange	め が ね フ ラ ン ジ	
	Blind flange	閉 止 フ ラ ン ジ	
	Orifice	オ リ フ ィ ス	
	Flexible pipe	フ レ キ シ ブ ル パ イ プ	
	Hopper	ホ ッ パ ー	
	Hopper with cover	ふ た 付 ホ ッ パ ー	
	Air pipe	空 気 抜 管	
	Loop seal pipe siphon	ル ー プ シ ー ル パ イ プ サ イ フ ォ ン	
	Siphon	サ イ フ ォ ン	

SYMBOLS 記 号	NAME	名 称	REMARKS 備 考
-----	Elect. cable	電 気 配 線	
-----	Outfit line (to be delivered By yard)	艀 装 所 掌 配 管	
	Pressure switch	圧 力 ス イ ッ チ	
	Temperature switch	温 度 ス イ ッ チ	
	Float switch	フ ロ ー ト ス イ ッ チ	
	Limit switch	リ ミ ッ ト ス イ ッ チ	
	Change over switch	切 換 ス イ ッ チ	
	Pressure transmitter	圧 力 ト ラ ン ス ミ ッ タ ー	
Bar Type 	Thermometer	温 度 計	
Dial Type 			
engine side 	Pressure gauge	圧 力 計	
on Gauge board 			
	U Tube manometer	U 字 管 式 圧 力 計	
	Stop valve	止 め 弁	Globe valve 玉 形 弁
			Angle valve ア ン グ ル 弁
	Thermometer pocket	温 度 計 座 (ポ ケ ッ ト 付)	
	Three-way cock	三 方 コ ッ ク	(1) T形 (T-PORT) (2) L形 (L-PORT)
	Butterfly valve	バ タ フ ラ イ 弁	
	Solenoid operated valve	電 磁 弁	

SYMBOLS 記号	NAME	名 称	REMARKS 備 考
	Solenoid operated valve (angle)	電 磁 弁	
	Gate valve	仕 切 弁	
	Hose valve	ホ ー ス 弁	
	Hose valve (angle)	ホ ー ス 弁 (アングル)	
	Safety valve	安 全 弁	
	Swing check valve	スイング逆止め弁	
	swing check valve (angle)	スイング逆止め弁 (アングル)	
	Lift check valve	リフト逆止め弁	
	Diaphragm operated valve (with positioner & handle)	ダイヤフラム操作弁 (ポジションナ及びハンドル付)	
	Sight glass	サ イ ト グ ラ ス	
	Simplex strainer	単 式 コ シ	
	Duplex strainer	復 式 コ シ	
	Y type strainer	Y形ストレーナ	
	Differential pressure gauge	差 圧 計	
	Reducer	レ ジ ュ ー サ	
	Hose coupling	ホ ー ス 継 手	
	Regulating valve	自 動 調 整 弁	
	Cock	コ ッ ク	
	Needle valve	ニ ー ド ル 弁	

SYMBOLS 記 号	NAME	名 称	REMARKS 備 考
	Remotely indicated (to be delivered By yard)	遠 隔 指 示 計	
PI	Pressure indication	圧 力 指 示	
PSD	Pressure slow down	圧 力 減 速	
PA	Pressure alarm	圧 力 警 報	
TI	Temperature indication	温 度 指 示	
TA	Temperature alarm	温 度 警 報	
TSD	Temperature slow down	温 度 減 速	
LI	Level indication	液 面 指 示	
LA	Oil or water level alarm	液 面 警 報	
FI	Flow indication	流 れ 指 示	
FA	Flow alarm	流 れ 警 報	
FSD	Flow slow down	流 れ 減 速	
DPA	Differential pressure alarm	差 圧 警 報	
H	High (high press.,high temp .,high level,high flow)	高 圧, 高 温, 高 液 面 高 流 量	 
L	Low (low press.,low temp .,low level,low flow)	低 圧, 低 温, 低 液 面 低 流 量	  ↑ For example
D	Deviation (Deviation temp)	温 度 偏 差 大	
	Fire alarm (Scavenging trunk)	掃 気 室 火 災 警 報	
TR	Temperature sensor	温 度 セ ン サ ー	

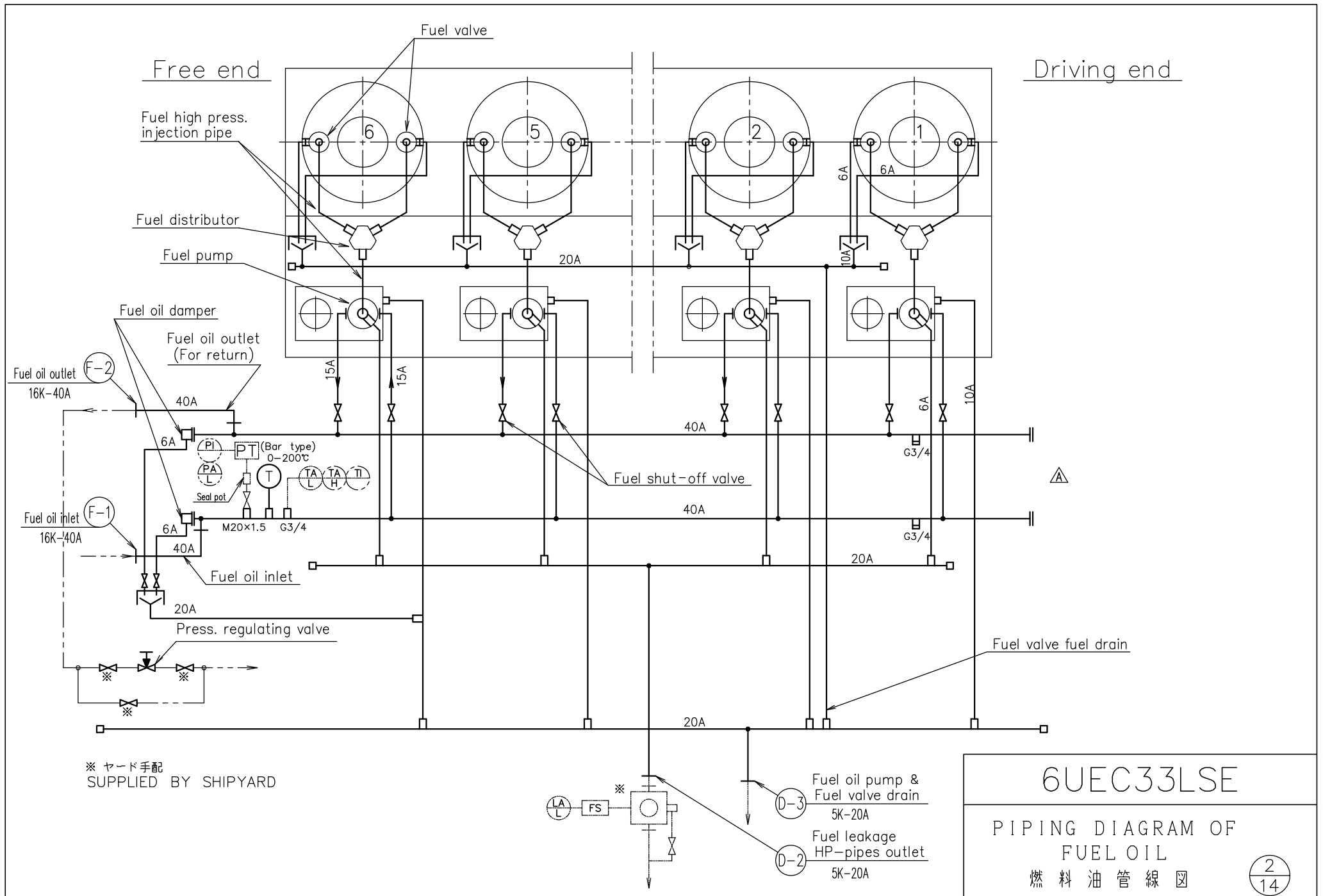

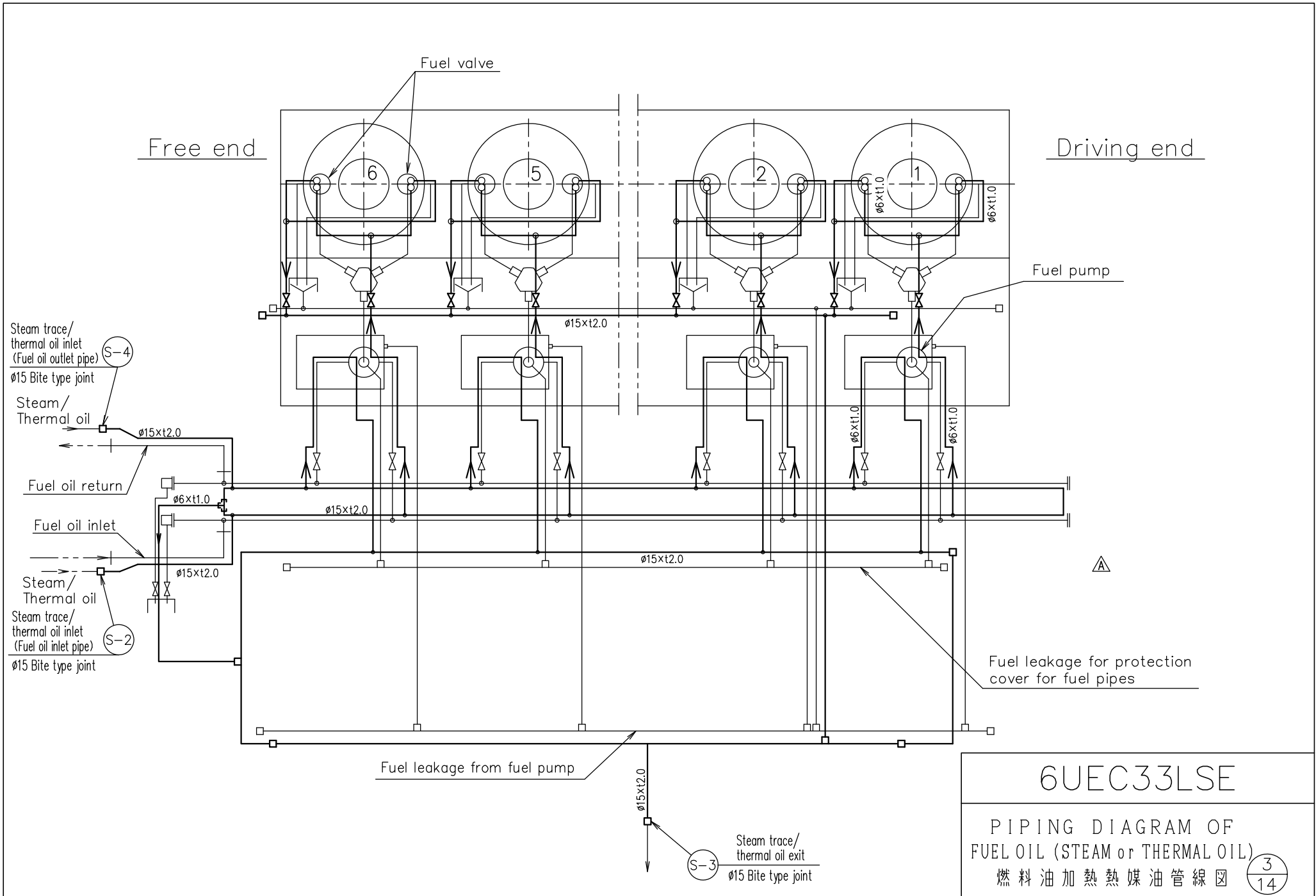

6UEC33LSE
 PIPING DIAGRAM OF
 FUEL OIL (STEAM or THERMAL OIL)
 燃料油加熱熱媒油管線圖

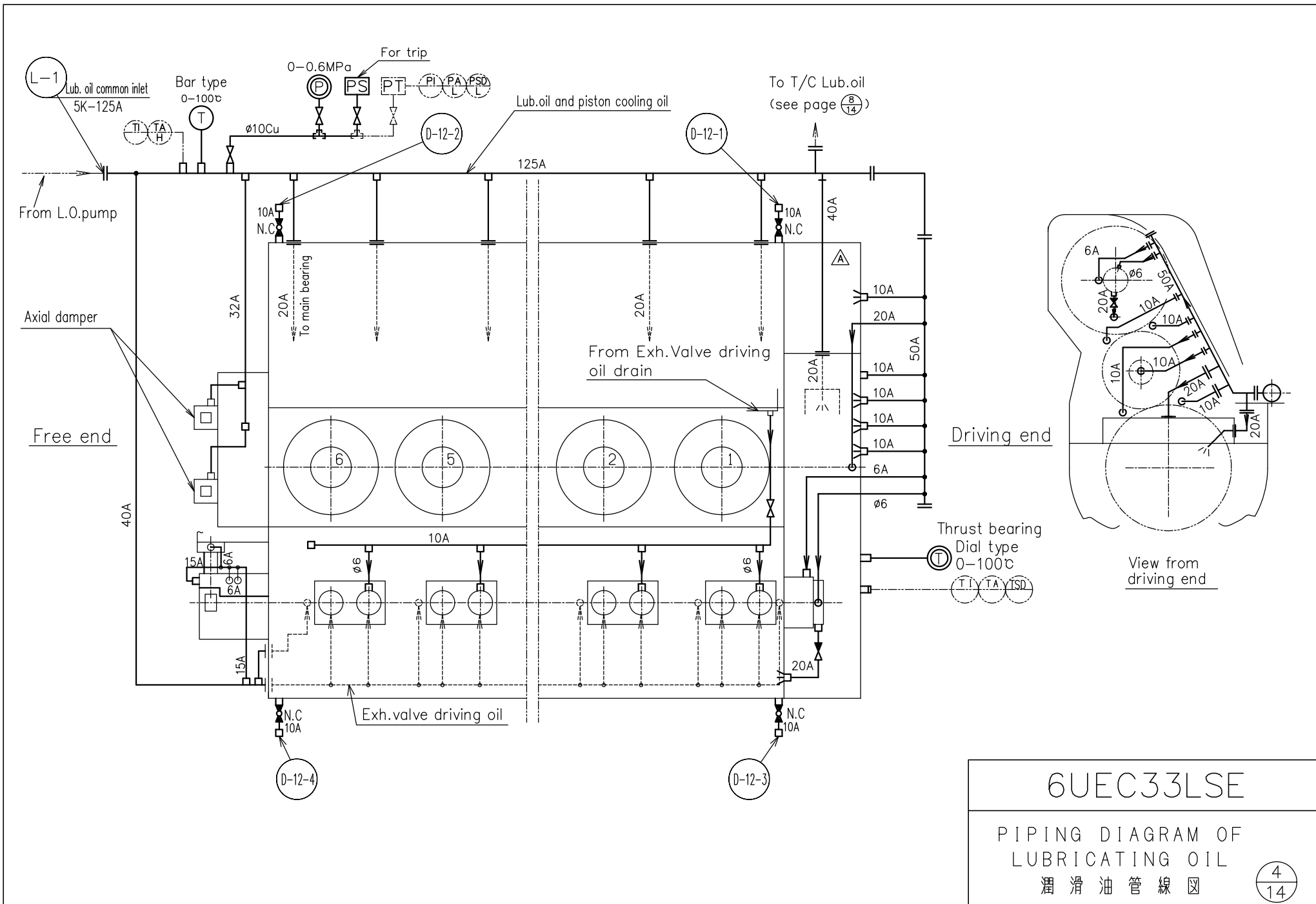

L-1
Lub. oil common inlet
5K-125A

Bar type
0-100°C

0-0.6MPa
For trip
PS PT PI PA PSD

Lub. oil and piston cooling oil

To T/C Lub. oil
(see page 8/14)

From L.O. pump

Axial damper

Free end

40A

32A

20A
To main bearing

From Exh. Valve driving
oil drain

Driving end

Thrust bearing
Dial type
0-100°C
TI TA TSD

View from
driving end

D-12-4

D-12-3

125A

D-12-1

40A

10A
N.C.

20A

10A

10A

10A

10A

10A

6A

50A

20A

ø6

6

5

2

1

ø6

ø6

ø6

ø6

15A

6A

6A

15A

N.C
10A

N.C
10A

Exh. valve driving oil

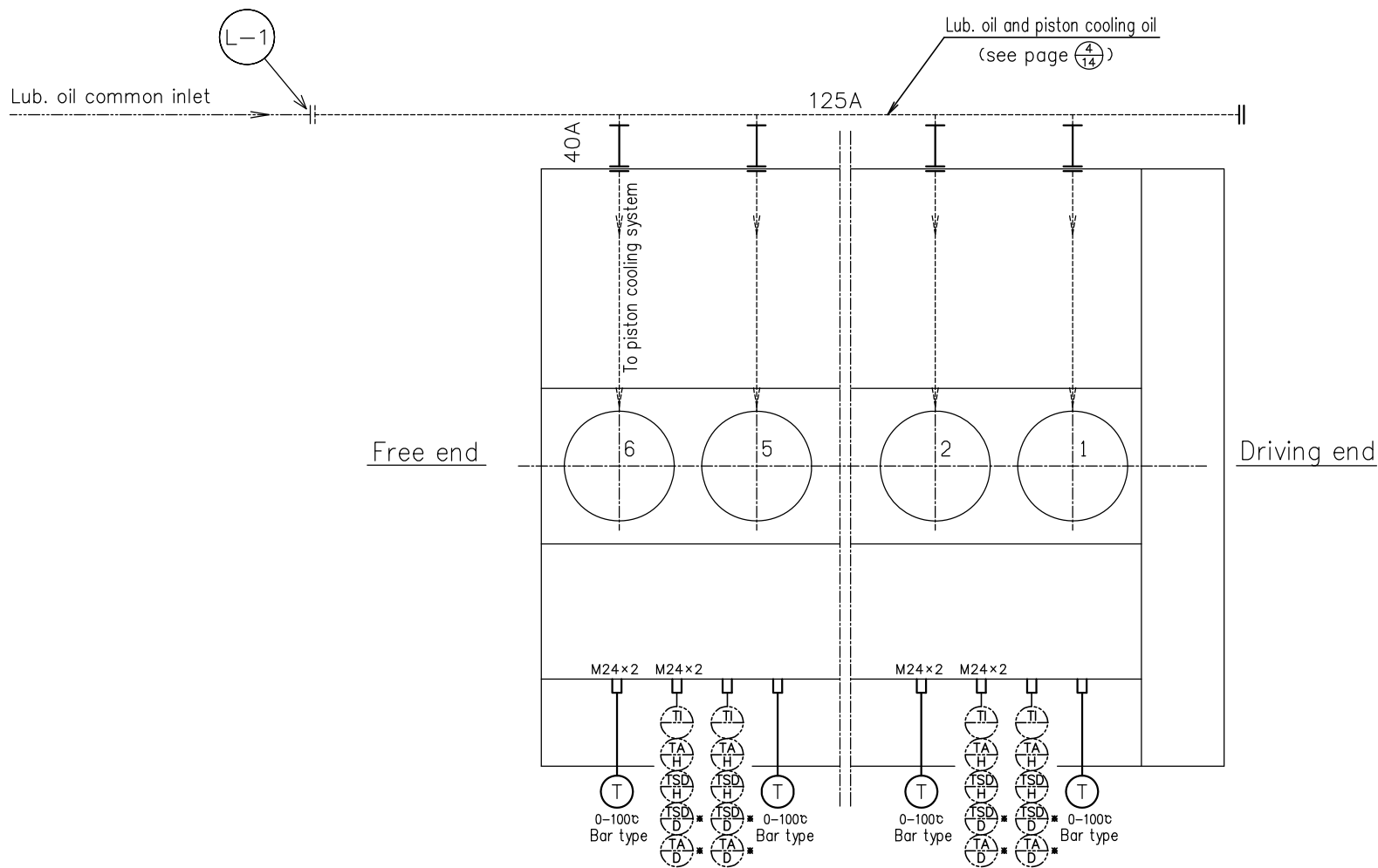

*As alternative to piston coolant flow sensor of each piston.

6UEC33LSE

PIPING DIAGRAM OF
PISTON COOLING OIL
ピストン冷却油管線図

5/14

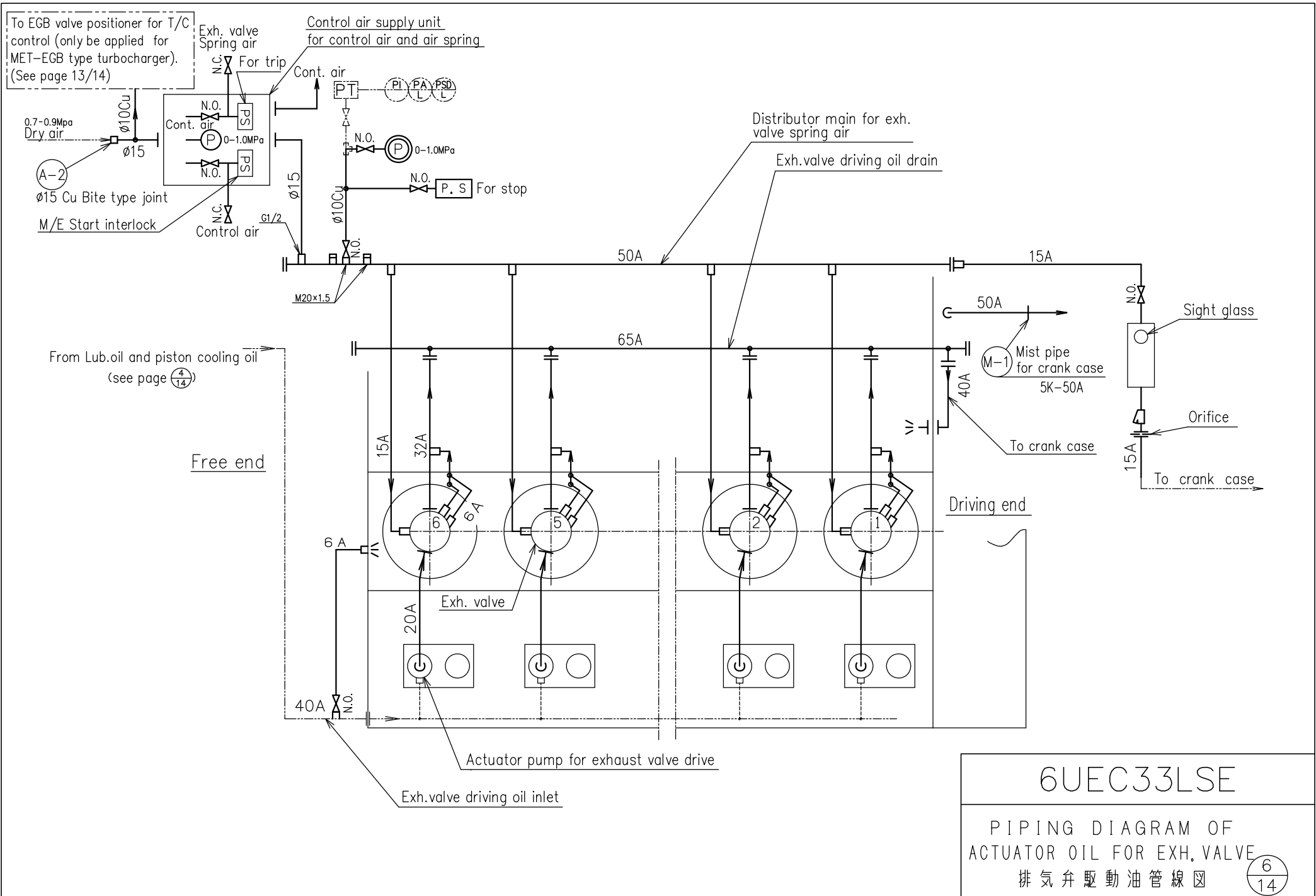

Cylinder lubricator inlet
5K-20A

L-3

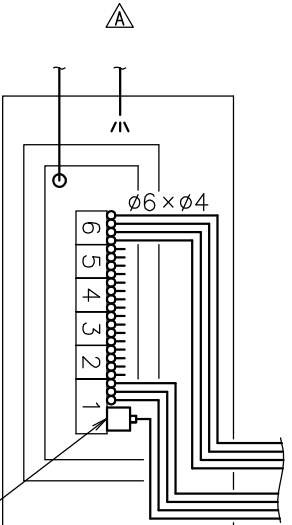
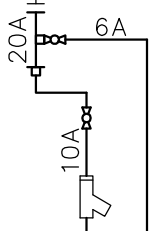

Non flow alarm
(for alarm & auto slow down)
Non flow alarm is attached to lubricator.

Oil tray for cyl.
lubricator drain

Non flow alarm with proximity switch

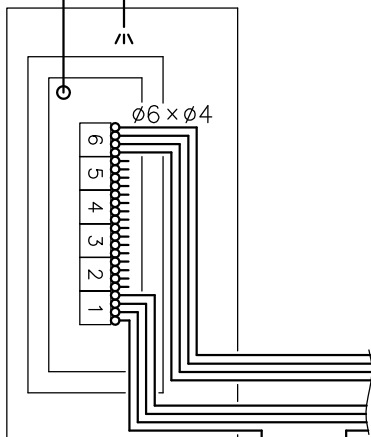

Oil tray for cyl.
lubricator drain

Non flow alarm
(for alarm & auto slow down)

Non flow alarm with flow switch

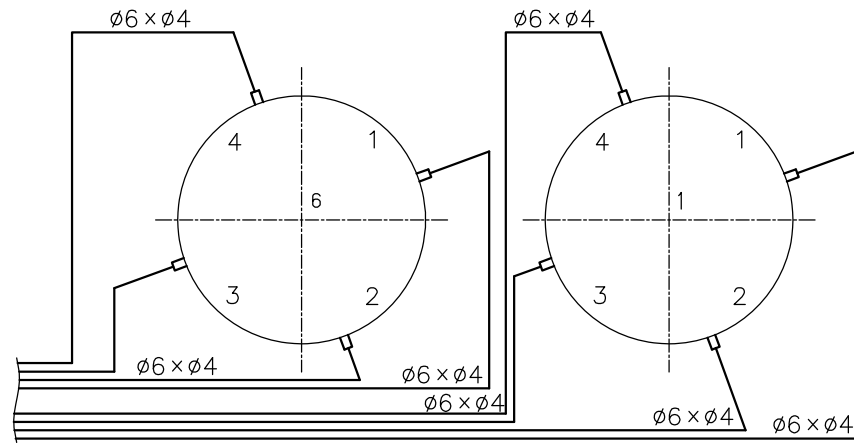

6UEC33LSE	
PIPING DIAGRAM OF CYLINDER LUBRICATING OIL	
シリンダ注油管線図	

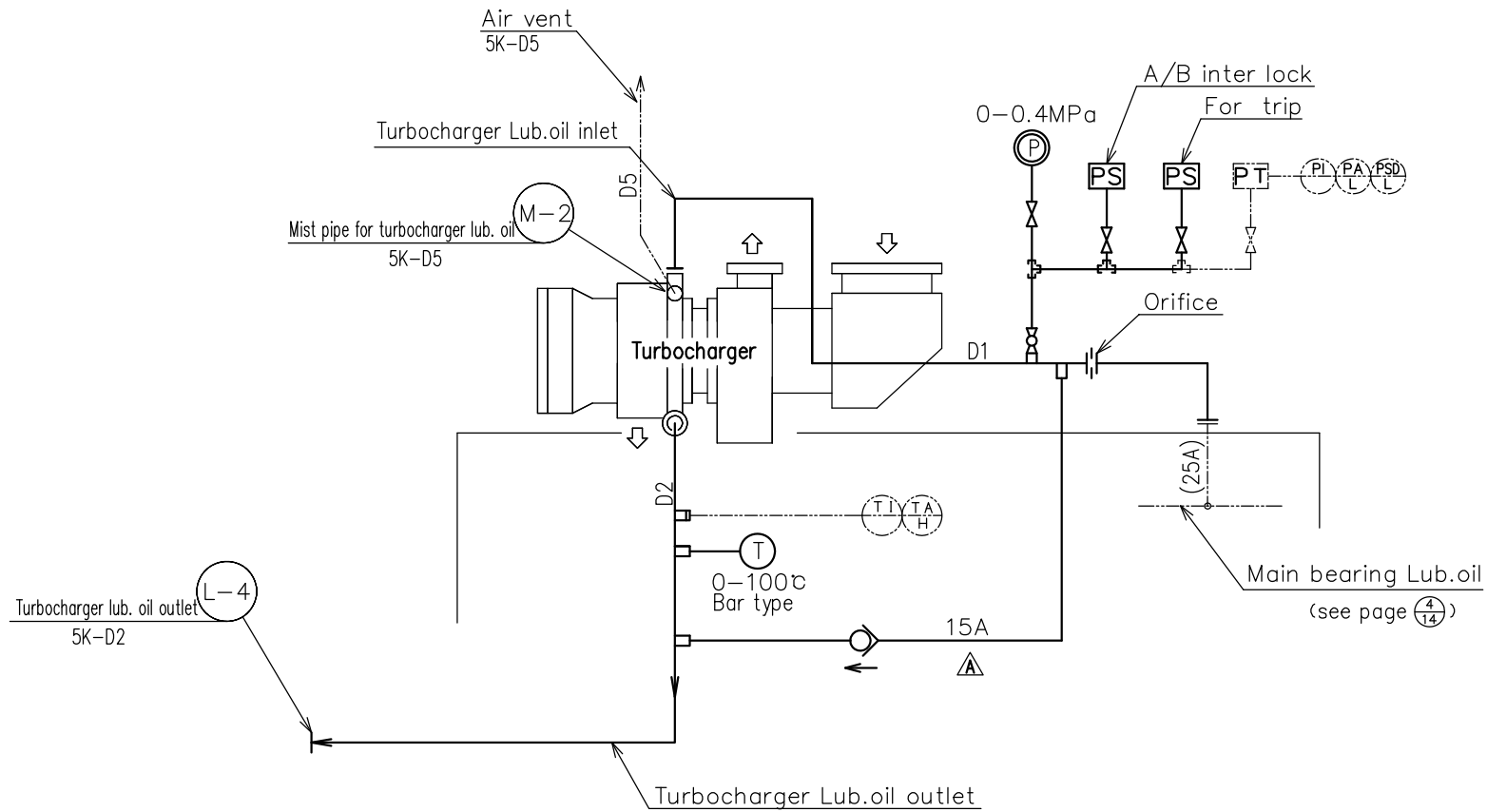

Turbocharger type	Pipe sizes		
	D1	D2	D5
MET33MB/-EGB×1	20A	40A	32A
MET37MB/-EGB×1	25A	50A	50A

6UEC33LSE

PIPING DIAGRAM OF
TURBO CHARGER LUB.OIL

過給機潤滑油管線図

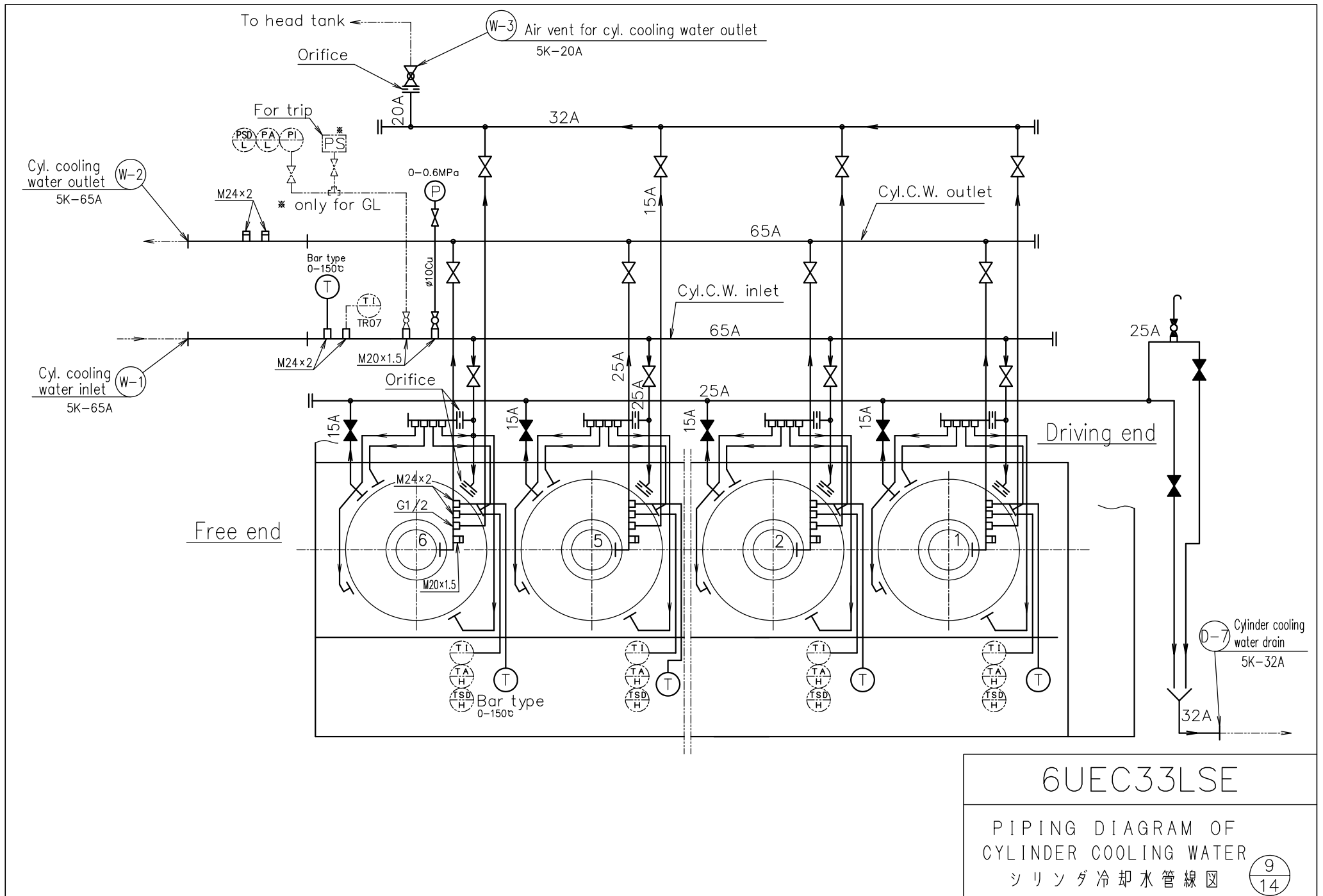

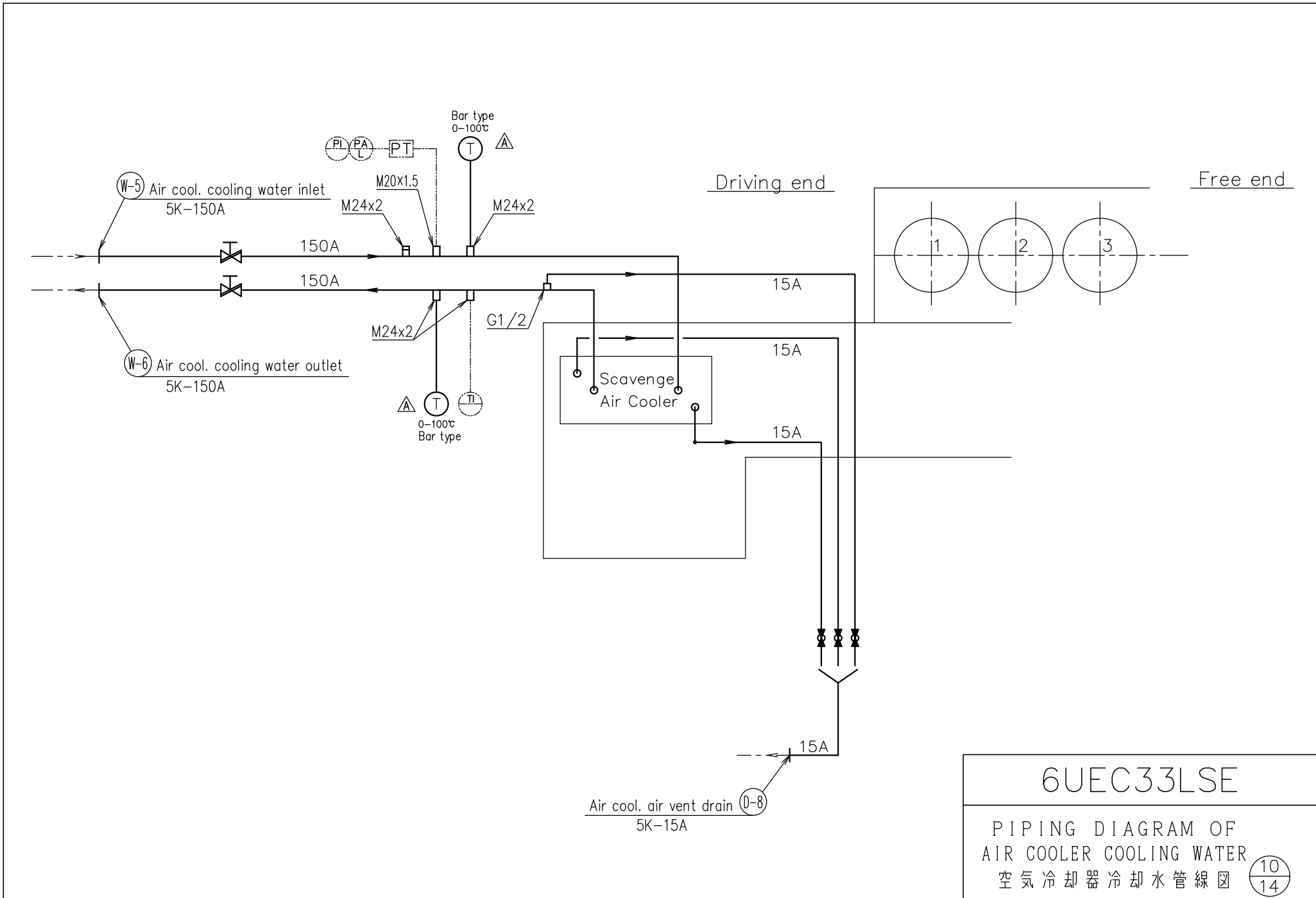

6UEC33LSE
 PIPING DIAGRAM OF
 AIR COOLER COOLING WATER
 空気冷却器冷却水管線図

Free end

Driving end

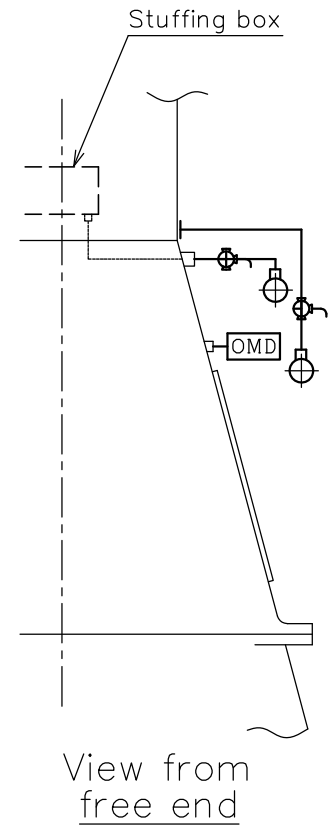
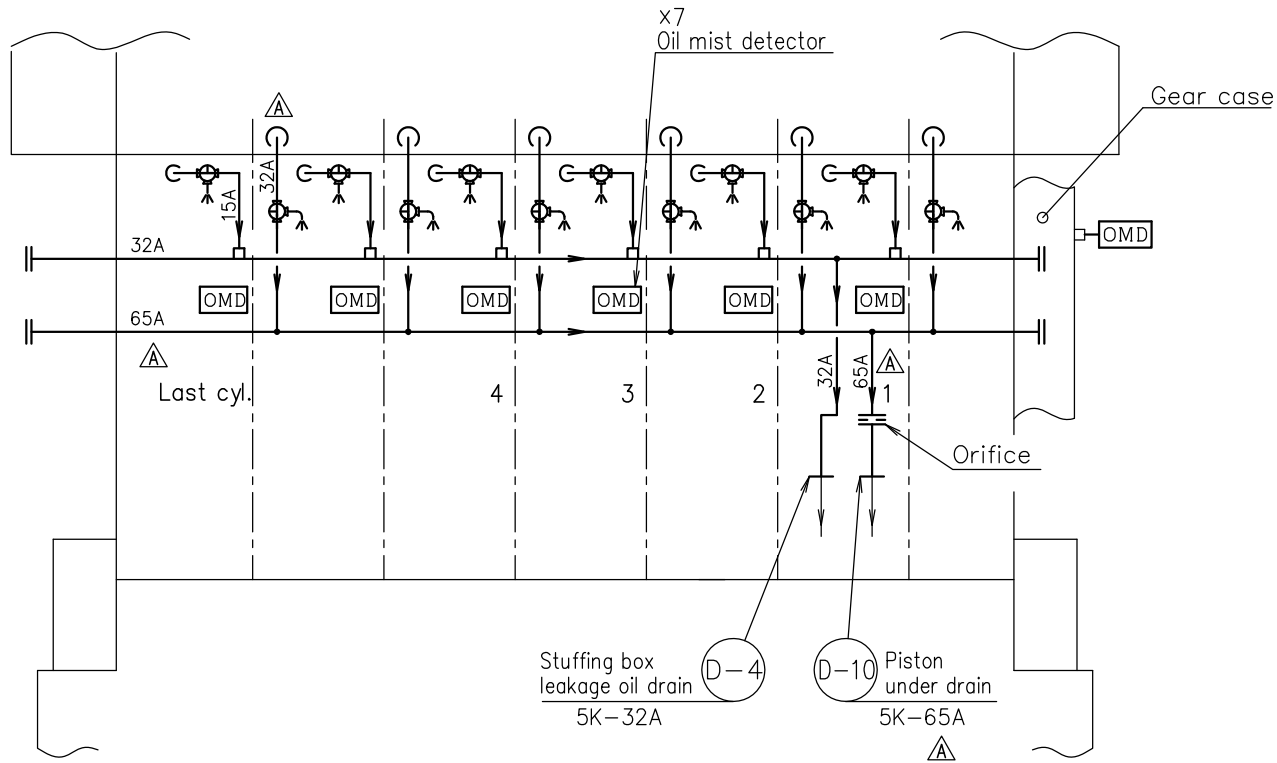

6UEC33LSE

PIPING DIAGRAM OF STUFFING BOX
LEAKAGE DRAIN AND PISTON UNDER DRAIN

ピストン棒パッキン箱ドレン管
及びシリンダ下部ドレン管線図

11
14

Driving end

Free end

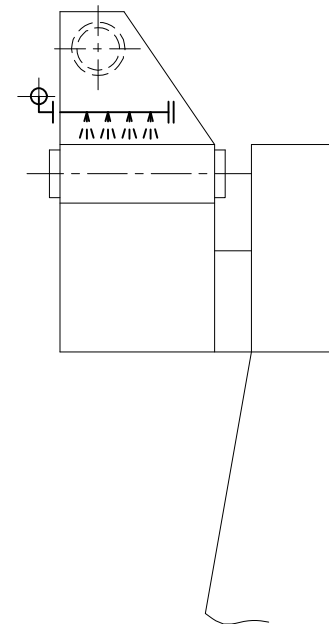
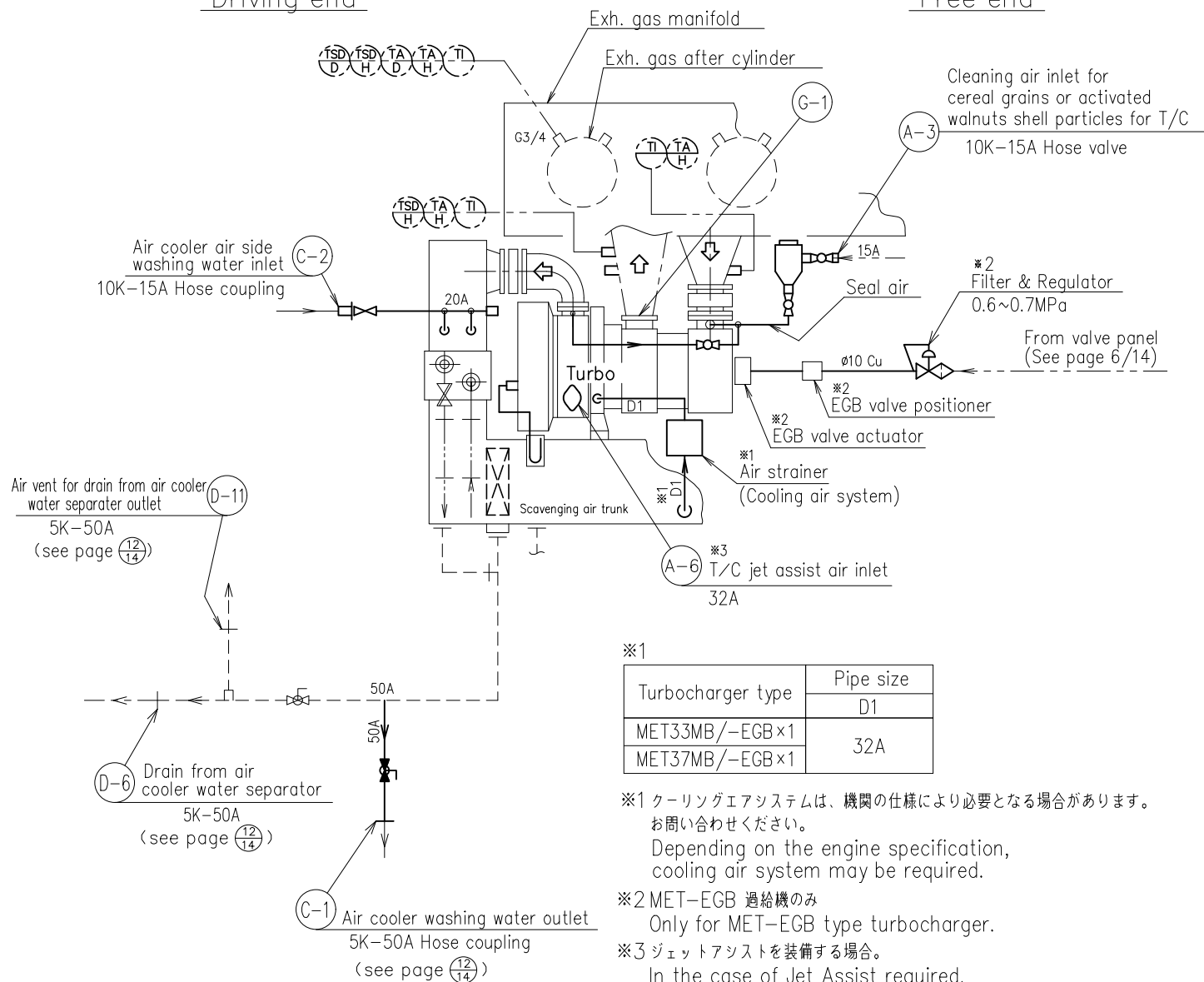

※1

Turbocharger type	Pipe size
MET33MB/-EGB×1	D1
MET37MB/-EGB×1	32A

※1 クーリングエアシステムは、機関の仕様により必要となる場合があります。お問い合わせください。

Depending on the engine specification, cooling air system may be required.

※2 MET-EGB 過給機のみ
Only for MET-EGB type turbocharger.

※3 ジェットアシストを装備する場合。
In the case of Jet Assist required.

6UEC33LSE
PIPING DIAGRAM OF TURBOCHARGER
AND AIR COOLER WASHING
WATER, AND EXHAUST GAS SYSTEM
過給機空気冷却器洗浄水管及び排気ガス線図

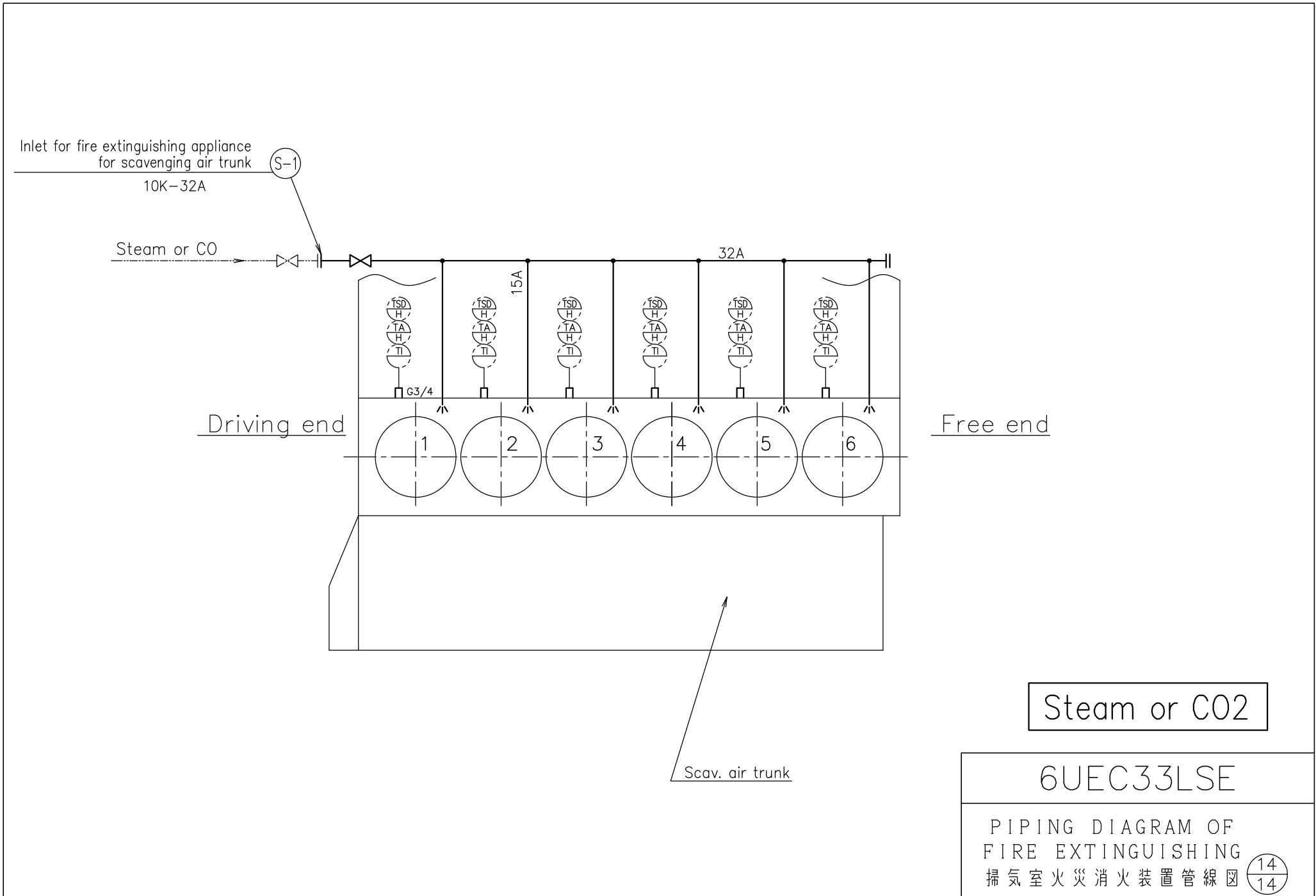

Inlet for fire extinguishing appliance
for scavenging air trunk
10K-32A

(S-1)

Steam or CO

32A

15A

G3/4

Driving end

1

2

3

4

5

6

Free end

Scav. air trunk

Steam or CO2

6UEC33LSE

PIPING DIAGRAM OF
FIRE EXTINGUISHING

掃気室火災消火装置管線図

14
14