

CUSTOMER	
SHIP NO.	
BUILDER	

Marks	Engine type	Turbocharger type	Tier3	Hydraulic supply oil
				Common system
01	6UEC42LSH-Eco-D3-EGR	MET37MB-EGBx1	x	x
		MET42MB-EGBx1	x	x
02	6UEC42LSH-Eco-D4-EGR	MET37MB-EGBx1	x	x
		MET42MB-EGBx1	x	x

x: Apply

DESTINATION	SERIAL NO.	MODEL 6UEC42LSH-Eco-EGR		
	ORDER NO.	<p style="text-align: center;">諸管線図集</p> <p style="text-align: center;">PIPING DIAGRAM</p>		
	ENGINEERING DEPARTMENT			
	APPROVED K. Edo			
	CHECKED Y. Kinoshita / S. Yoshikawa			
	DRAWN T. Hamanishi	DATE Jun.28, 2019	DRAWING NO.	REV.
Total	SHEETS 31 (with cover)	SHEETS U7-0M002	R	

諸管線図名称











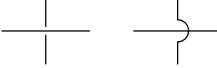
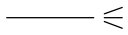
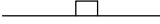

Name of piping diagram



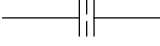







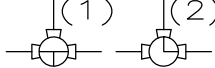

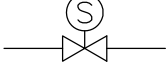
			-D3	-D4
U7-0M002	① 19	Starting air 始動空気管線図	×	×
"	② 19	Fuel oil 燃料油管線図 (For D3)	×	
"	② 19	Fuel oil 燃料油管線図 (For D4)		×
"	③ 19	Fuel oil steam 燃料油加熱蒸気管線図 (For D3)	×	
"	③ 19	Fuel oil steam 燃料油加熱蒸気管線図 (For D4)		×
"	④ 19	Lubricating oil 潤滑油管線図	×	×
"	⑤-1 19	Axial damper oil 縦振動ダンパー油管線図	×	×
"	⑤-2 19	Axial damper oil (with free end casing) 縦振動ダンパー油管線図 (前端ケーシング付)	×	×
"	⑥ 19	Piston cooling oil ピストン冷却油管線図	×	×
"	⑦ 19	Hydraulic supply oil (Common system) (For D3) 油圧作動油管線図 (共油系統)	×	
"	⑦ 19	Hydraulic supply oil (Common system) (For D4) 油圧作動油管線図 (共油系統)		×
"	⑧ 19	Actuator oil for exhaust valve 排気弁駆動油管線図	×	×
"	⑨ 19	Cylinder lubricating oil for A-ECL system シリンダ注油管線図 (A-ECLシステム)	×	×
"	⑩ 19	Turbocharger lubricating oil 過給機潤滑油管線図	×	×
"	⑪ 19	Cylinder cooling water シリンダ冷却水管線図	×	×
"	⑫ 19	Air cooler cooling water 空気冷却器冷却水管線図	×	×
"	⑬ 19	Piston rod stuffing box drain ピストン棒パッキン箱ドレン管線図	×	×
"	⑭ 19	Scavenging air trunk drain (For EGR) 掃気トランクドレン管線図	×	×
"	⑮ 19	Turbocharger and air cooler washing water and exhaust gas system 過給機空気冷却器洗浄水管及び排気ガス線図	×	×
"	⑯ 19	Fire extinguishing 掃気室火災消火装置管線図	×	×
"	⑰ 19	Piping diagram for EGR gas system EGRガス線図	×	×
"	⑱ 19	Piping diagram for EGR scrubbing water system (On engine) EGRスクラバ水線図	×	×
"	⑲ 19	Piping diagram for EGR scrubbing water system (Hull side) EGRスクラバ水線図	×	×

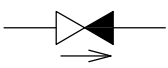

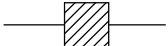
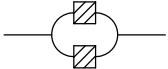

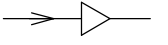

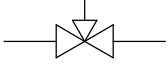
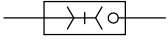
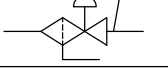
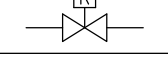
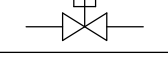











× : Apply

SYMBOLS FOR MAIN ENGINE PIPING DIAGRAM

主 機 関 諸 管 線 図 記 号

SYMBOLS 記 号	NAME	名 称	REMARKS 備 考
	<u>Nominal inner diameter</u>	<u>称呼口径</u>	
	Crossing pipes, connected	連結管	
	Crossing pipes, not connected	不連結管	
	To bilge	ビルジへ	
	Boss	ボス	
	Boss with plug	プラグ付ボス	
	Joint, bossed	ボス継手	
	Joint, flanged	フランジ継手	
	Blind flange	閉止フランジ	
	Orifice	オリフィス	
	Flexible pipe	フレキシブルパイプ	
	Hopper	ホッパー	
	Hopper with cover	ふた付ホッパー	
	Air vent pipe	空気抜管	
	Siphon	サイフォン	
	Air chamber	エアチャンバー	

SYMBOLS 記号	NAME	名 称	REMARKS 備 考
	Stop valve	止め弁	
	Three-way cock	三方コック	(1) T形 (T-PORT) (2) L形 (L-PORT)
	Butterfly valve	バタフライ弁	
	Solenoid operated valve	電磁弁	
	Gate valve	仕切弁	
	Safety valve	安全弁	
	Check valve	逆止弁	
	Sight glass	サイトグラス	
	Simplex strainer	単式コシ	
	Duplex strainer	復式コシ	
	Y type strainer	Y形ストレーナ	
	Reducer	レジュース	
	Hose coupling	ホース継手	
	Regulating valve	自動調整弁	
	Self-seal joint	セルフシール継手	
	Filter and regulator	フィルタ及び調圧弁	
	Remote control valve	遠隔制御弁	
	Control valve	制御弁	
	Back pressure valve	背圧弁	
	Regulator	レギュレータ	

SYMBOLS 記号	NAME	名称	REMARKS 備考
	Pressure switch	圧力スイッチ	
	Temperature switch	温度スイッチ	
	Float switch	フロートスイッチ	
	Limit switch	リミットスイッチ	
	Pressure transmitter	圧力トランスミッター	
	Temperature sensor	温度センサ	
	O ₂ concentration sensor	O ₂ 濃度センサ	
	Mist sensor	ミストセンサ	
	Smoke sensor	スモークセンサ	
	Oil or water level sensor	液面レベルセンサ	
	Differential pressure switch	差圧スイッチ	
Bar type 	Thermometer	温度計	
Dial type 			
Engine side 	Pressure gauge	圧力計	
on Gauge board 			
	U Tube manometer	U字管式圧力計	
	Differential pressure gauge	差圧計	
	Oil mist detector	オイルミスト警報装置	

SYMBOLS 記号	NAME	名称	REMARKS 備考
	Remotely indicated	遠隔指示計	
PI	Pressure indication	圧力指示	
PA	Pressure alarm	圧力警報	
DPA	Differential pressure alarm	差圧警報	
PSD	Pressure slow down	圧力減速	
TI	Temperature indication	温度指示	
TA	Temperature alarm	温度警報	
TSD	Temperature slow down	温度減速	
LI	Level indication	液面指示	
LA	Oil or water level alarm	液面指示	
FI	Flow indication	流れ指示	
FA	Flow alarm	流れ警報	
FSD	Flow slow down	流れ減速	
OI	O ₂ concentration indication	O ₂ 濃度指示	
OA	O ₂ concentration alarm	O ₂ 濃度警報	
MSA	Mist alarm	ミスト警報	
ASD	Auto slow down	自動減速	
pHIA	pH indication, alarm	pH指示、警報	
DIA	Density indication, alarm	比重指示、警報	

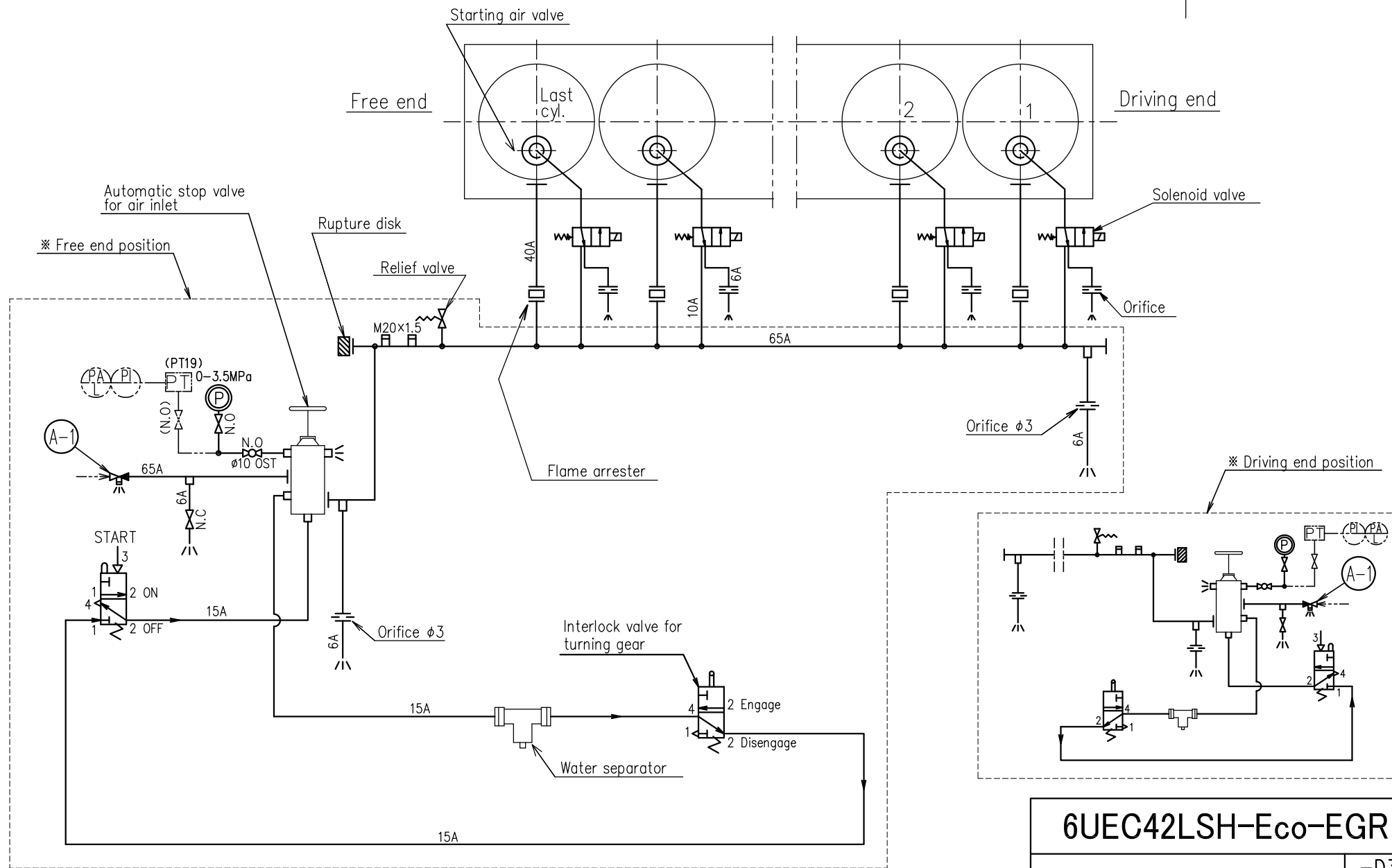

※ That of selecting one of the other.
 どちらか一方を選択のこと。

6UEC42LSH-Eco-EGR

Piping diagram of
 starting air

始動空気管線図

-D3
 -D4
 1/19

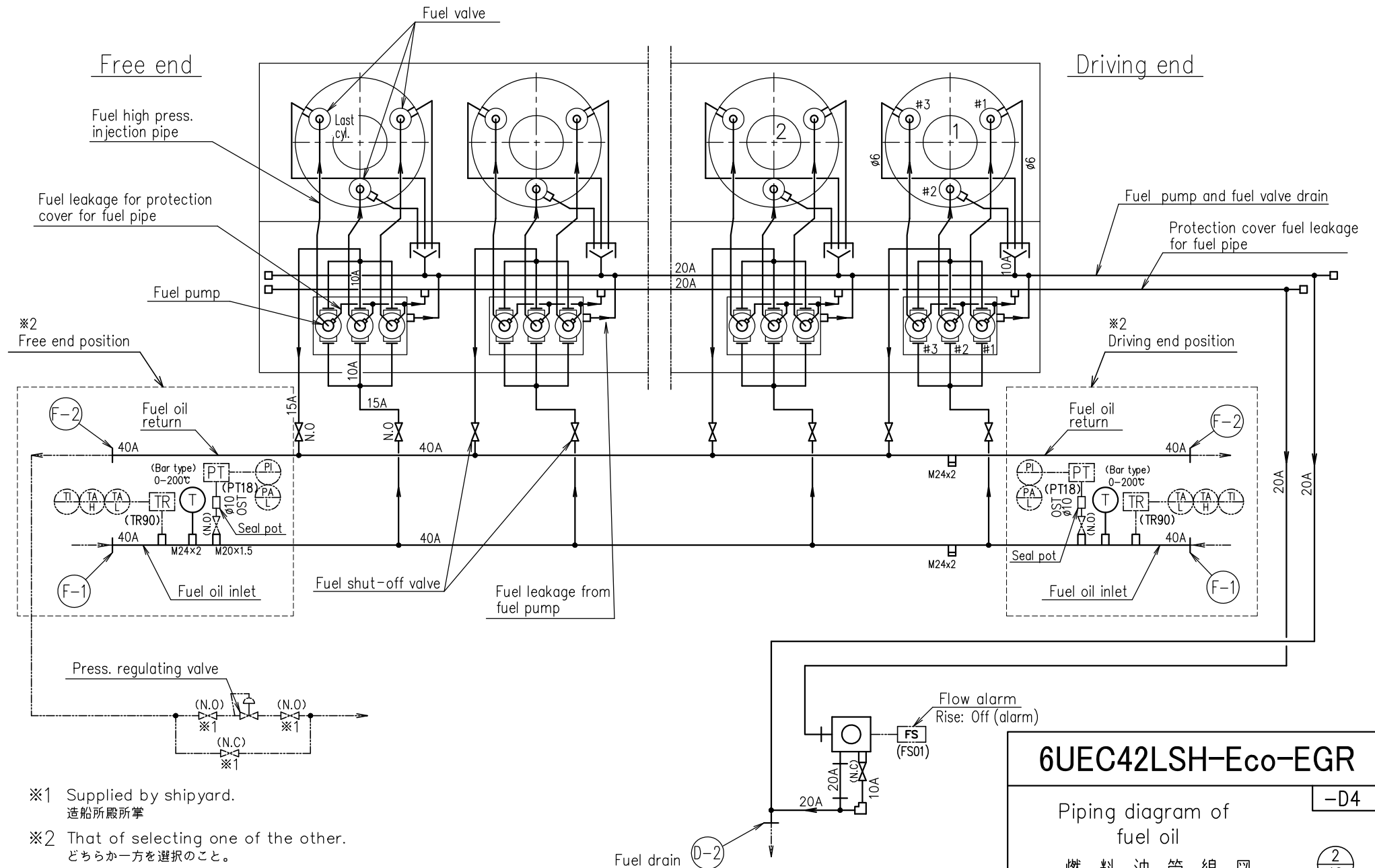

※1 Supplied by shipyard.
造船所蔵所掌

※2 That of selecting one of the other.
どちらか一方を選択のこと。

6UEC42LSH-Eco-EGR

Piping diagram of
fuel oil

燃料油管線図

-D4

2/19

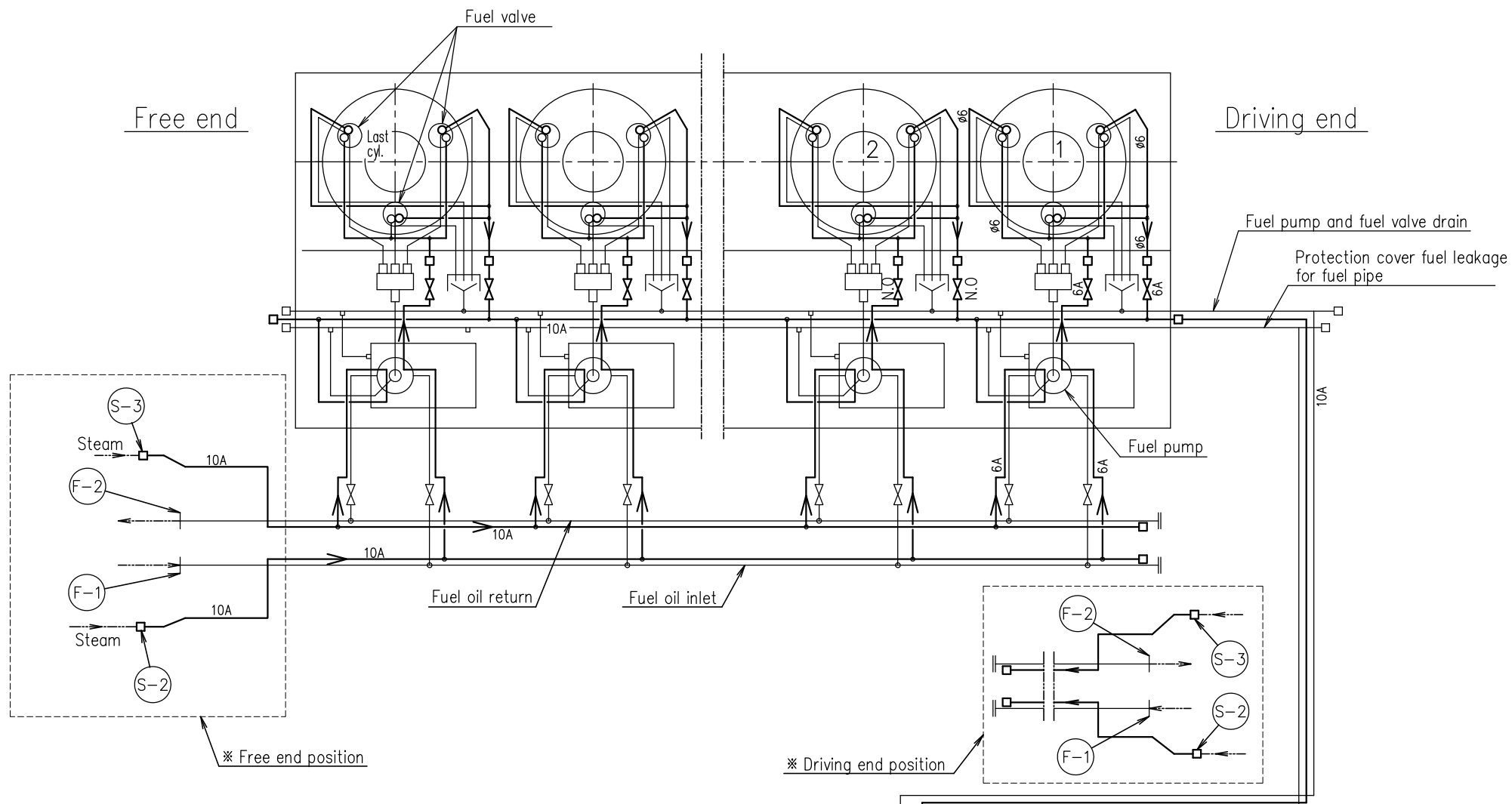

※ That of selecting one of the other.
 どちらか一方を選択のこと。

6UEC42LSH-Eco-EGR

Piping diagram of
 fuel oil steam

燃料油加熱蒸気管線図

-D3

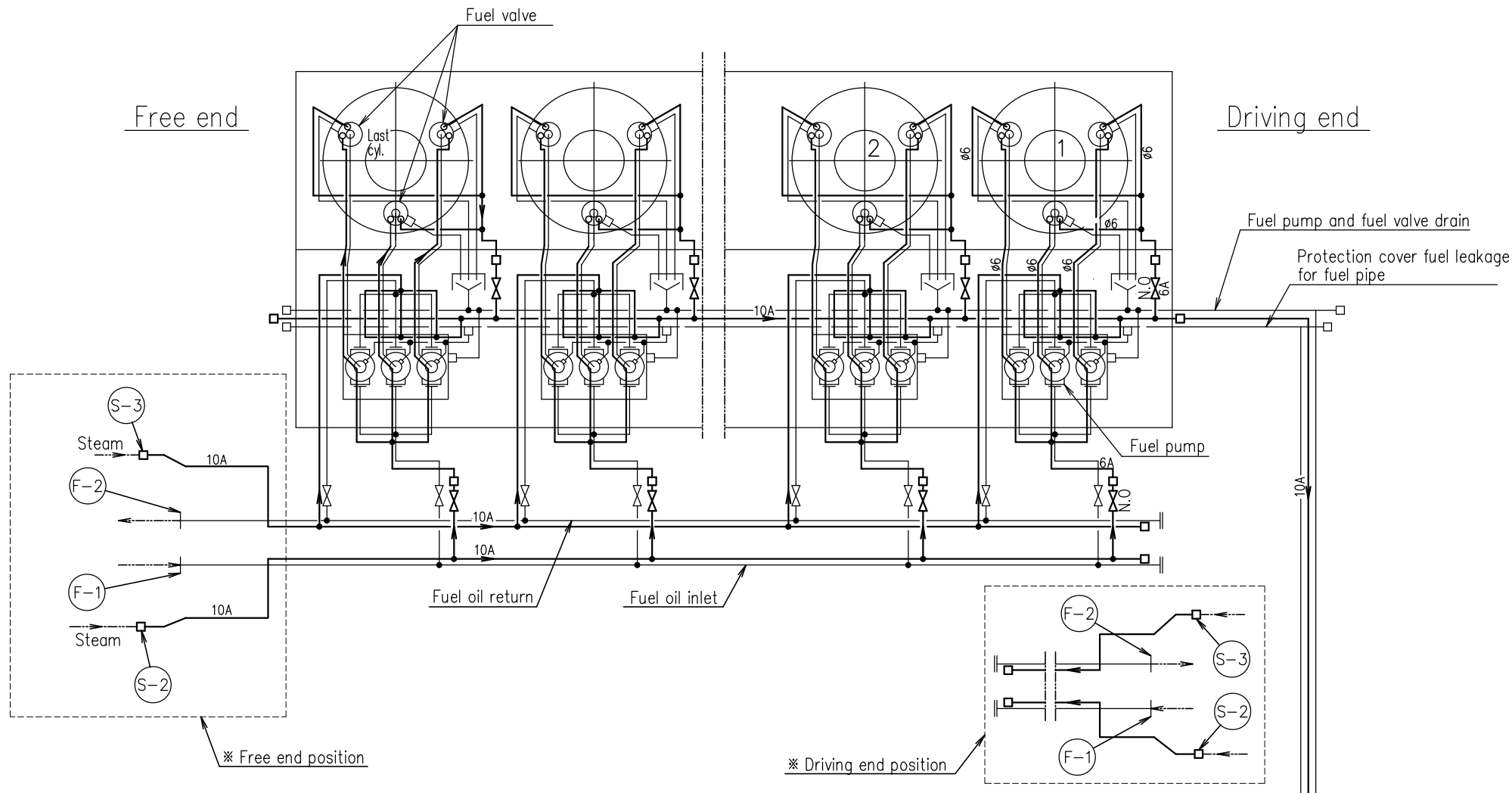

※ That of selecting one of the other.
 どちらか一方を選択のこと。

6UEC42LSH-Eco-EGR

Piping diagram of
 fuel oil steam

燃料油加熱蒸気管線図

-D4

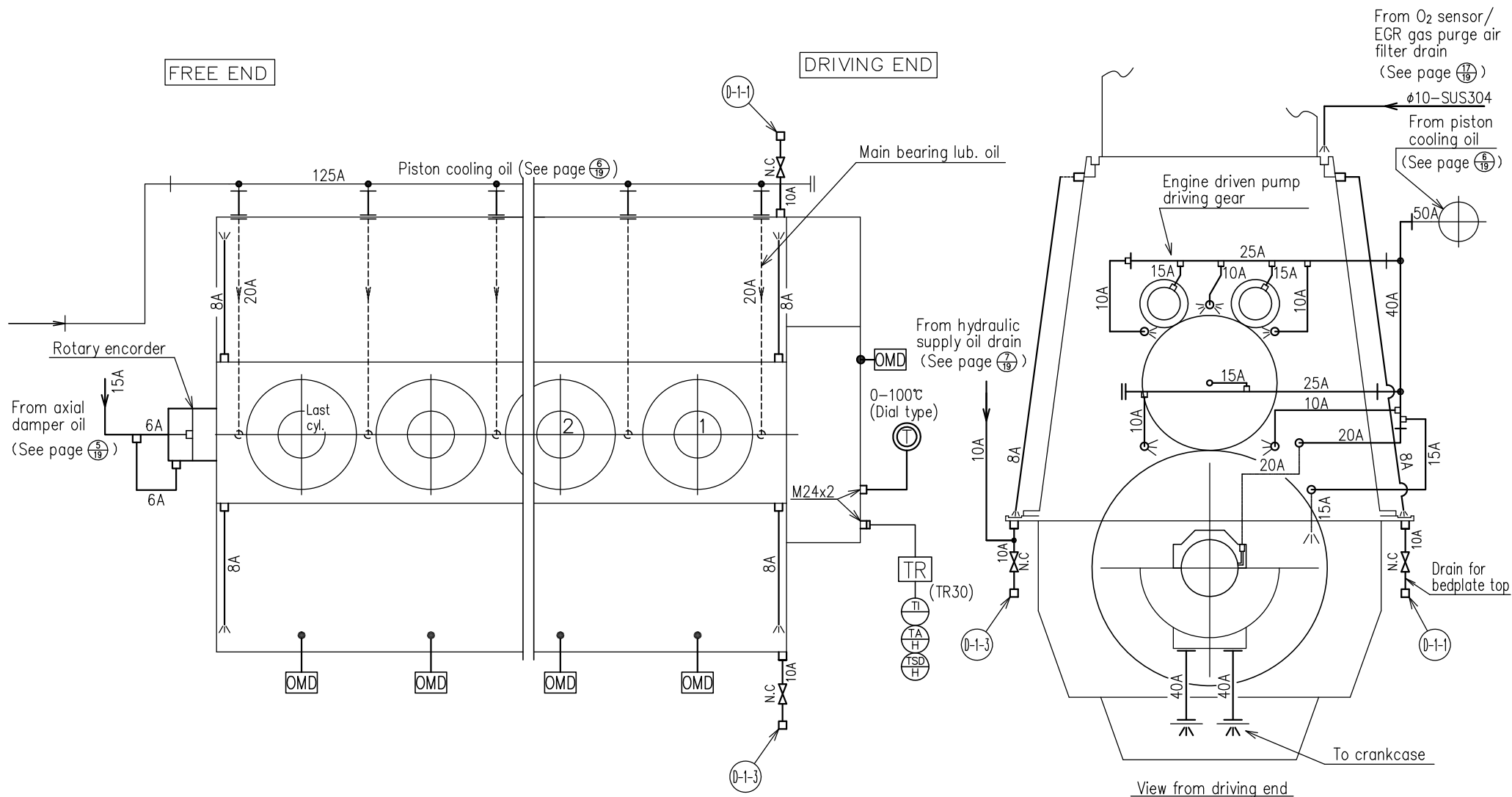

6UEC42LSH-Eco-EGR

Piping diagram of lubricating oil

潤滑油管線図

-D3
-D4

4
19

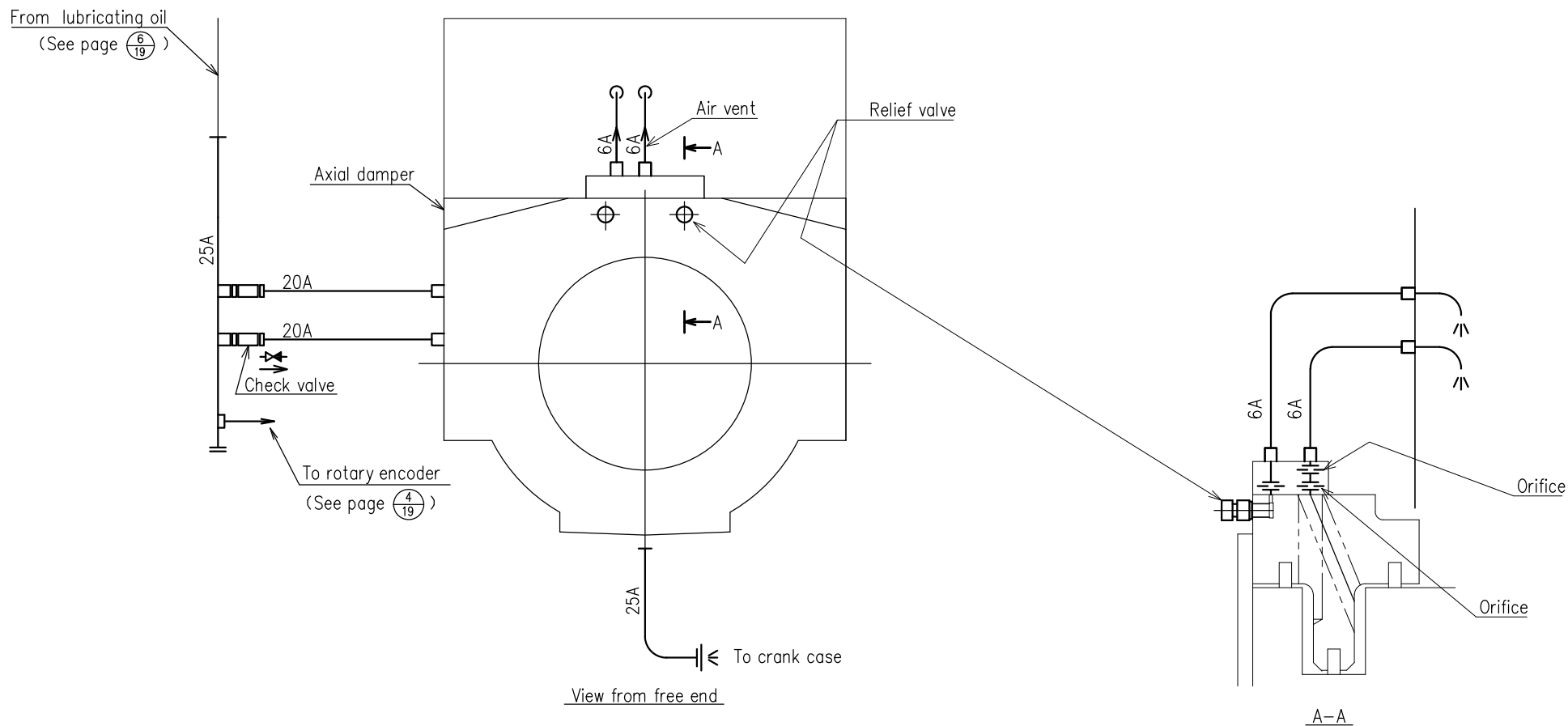

6UEC42LSH-Eco-EGR

Piping diagram of
axial damper oil

縦振動ダンパー油管線図

-D3
-D4

5-1
19

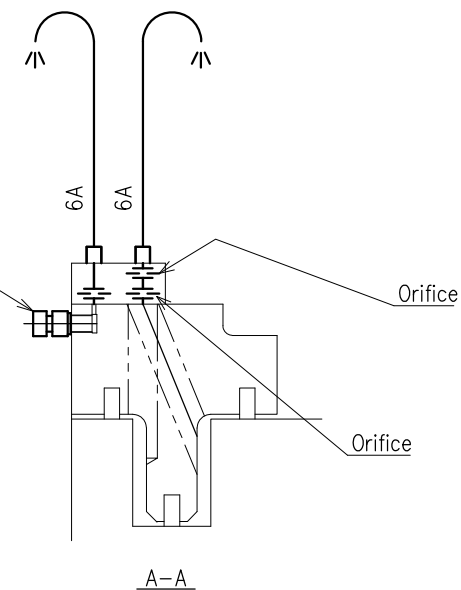
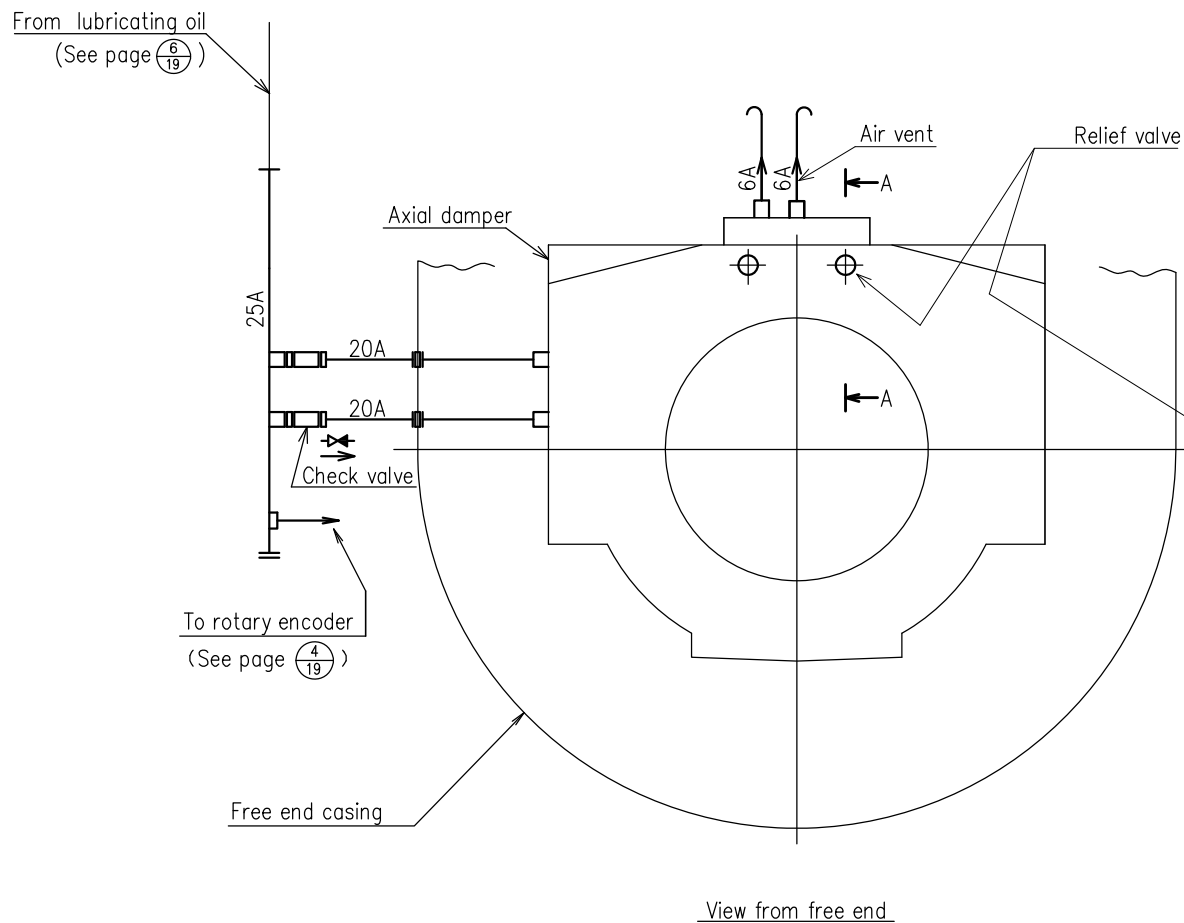

6UEC42LSH-Eco-EGR

Piping diagram of
axial damper oil

縦振動ダンパー油管線図

-D3
-D4

5-2
19

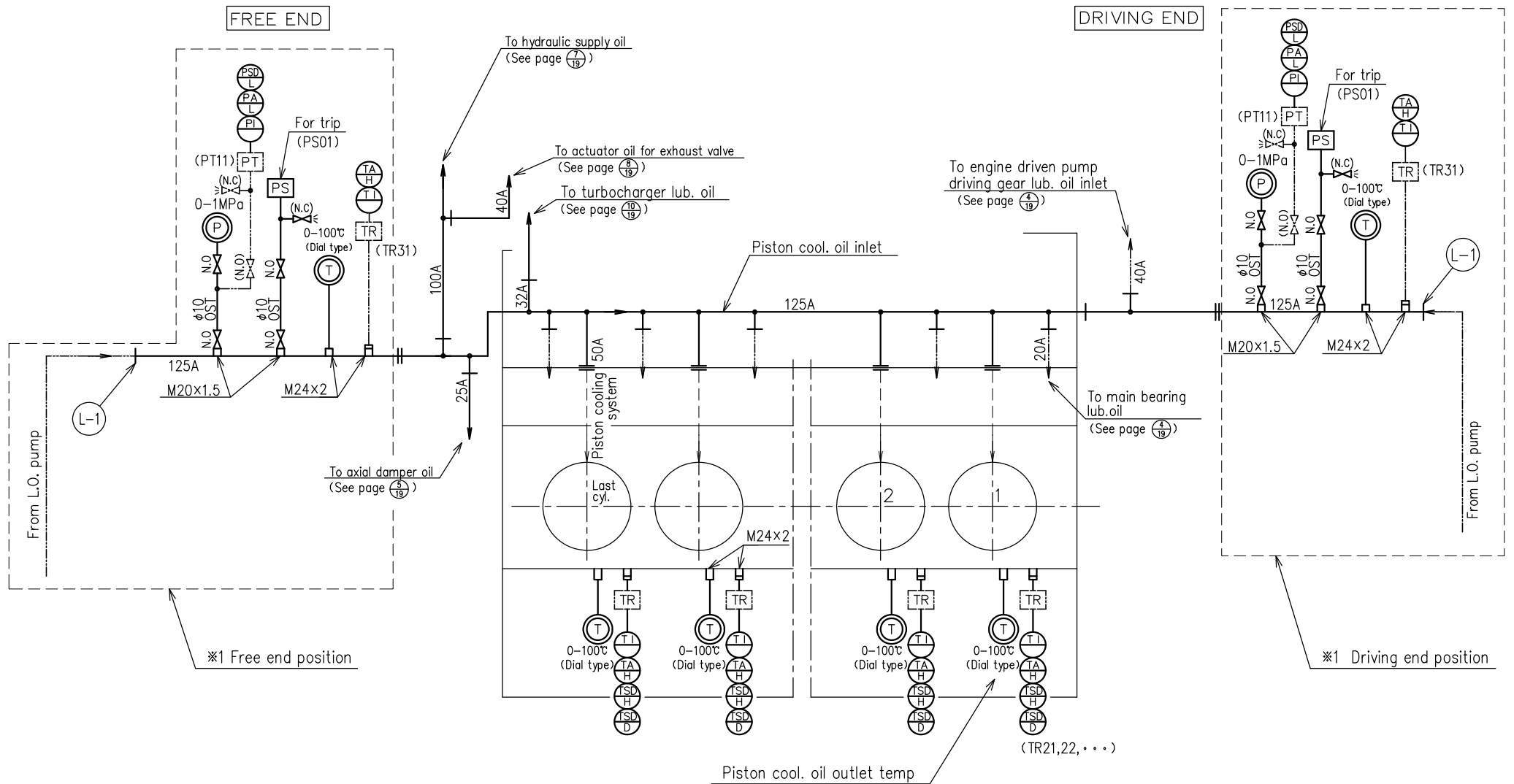

※1 Free end position

※1 Driving end position

※1 That of selecting the one of the other.
 どちらか一方を選択のこと。

6UEC42LSH-Eco-EGR	
Piping diagram of piston cooling oil ピストン冷却油管線図	-D3
	-D4
	6/19

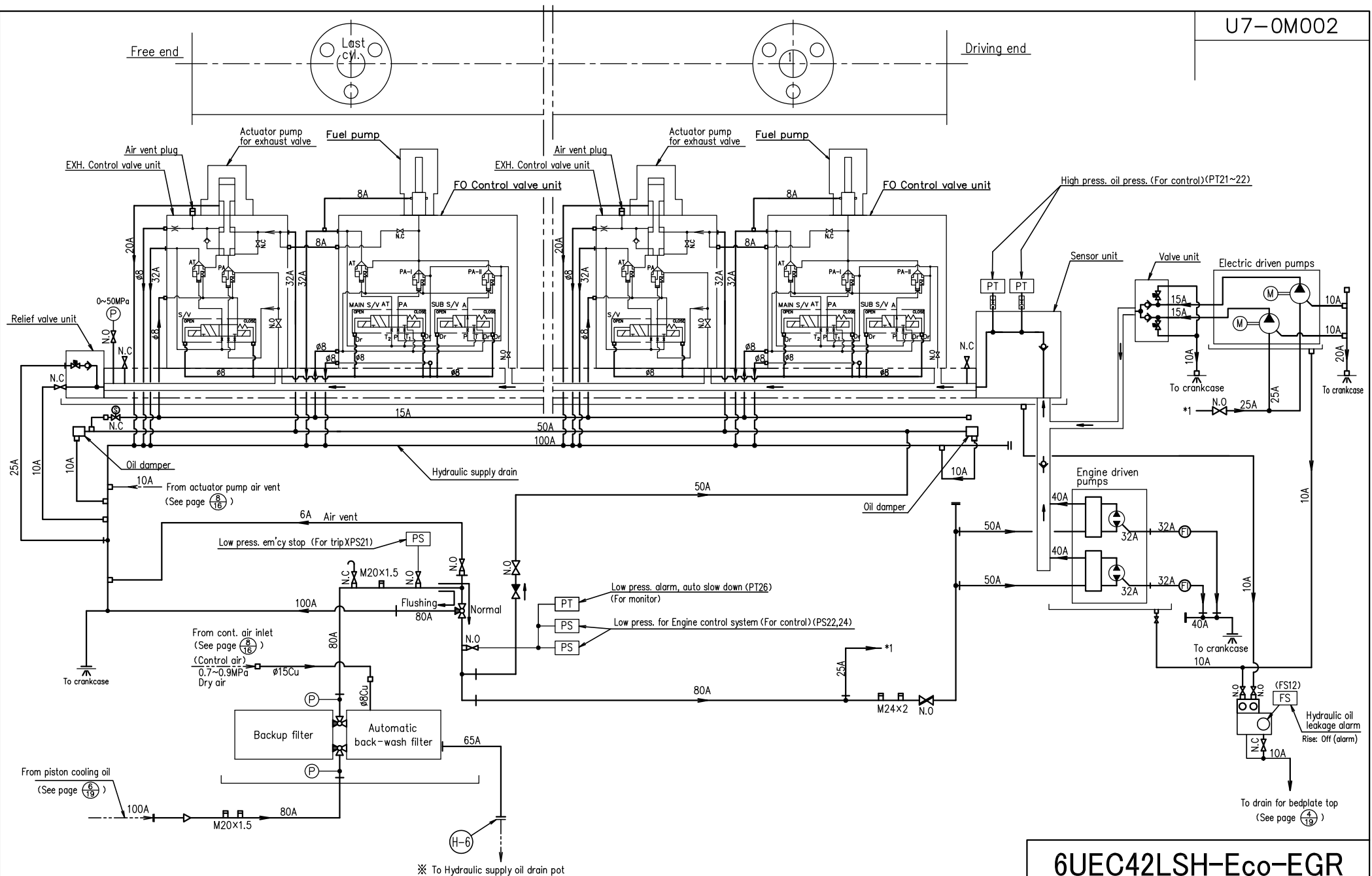

※ To Hydraulic supply oil drain pot

※ May not stand up the pipe to prevent the oil reservoir until the drain tank.
 And shall be contact the engine manufacturer if there is a need to stand up the pipe.
 ドレンタンクまで油溜まりができないように管に立ち上げ部を作らないこと。
 配管を立ち上げる必要がある場合はエンジンメーカーに問い合わせること。

6UEC42LSH-Eco-EGR

Piping diagram of hydraulic supply oil (Common system)

油圧作動油管線図 (共油系統)

-D3

7/19

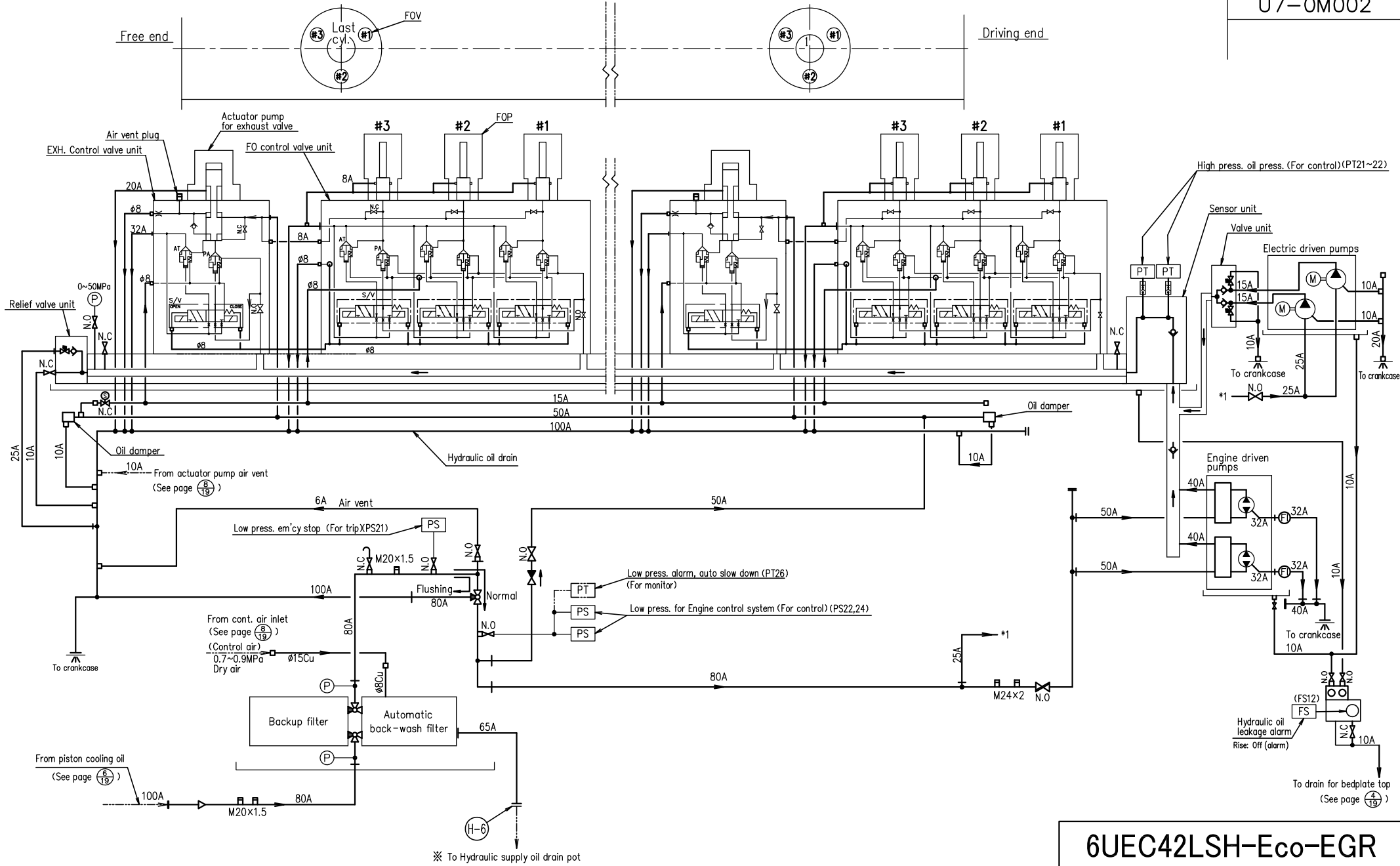

6UEC42LSH-Eco-EGR

Piping diagram of hydraulic supply oil (Common system)

油圧作動油管線図 (共油系統)

-D4

7/19

※ May not stand up the pipe to prevent the oil reservoir until the drain tank.
And shall be contact the engine manufacturer if there is a need to stand up the pipe.
ドレンタンクまで油溜まりができないように管に立ち上げ部を作らないこと。
配管を立ち上げる必要がある場合はエンジンメーカーに問い合わせること。

DRIVING END

FREE END

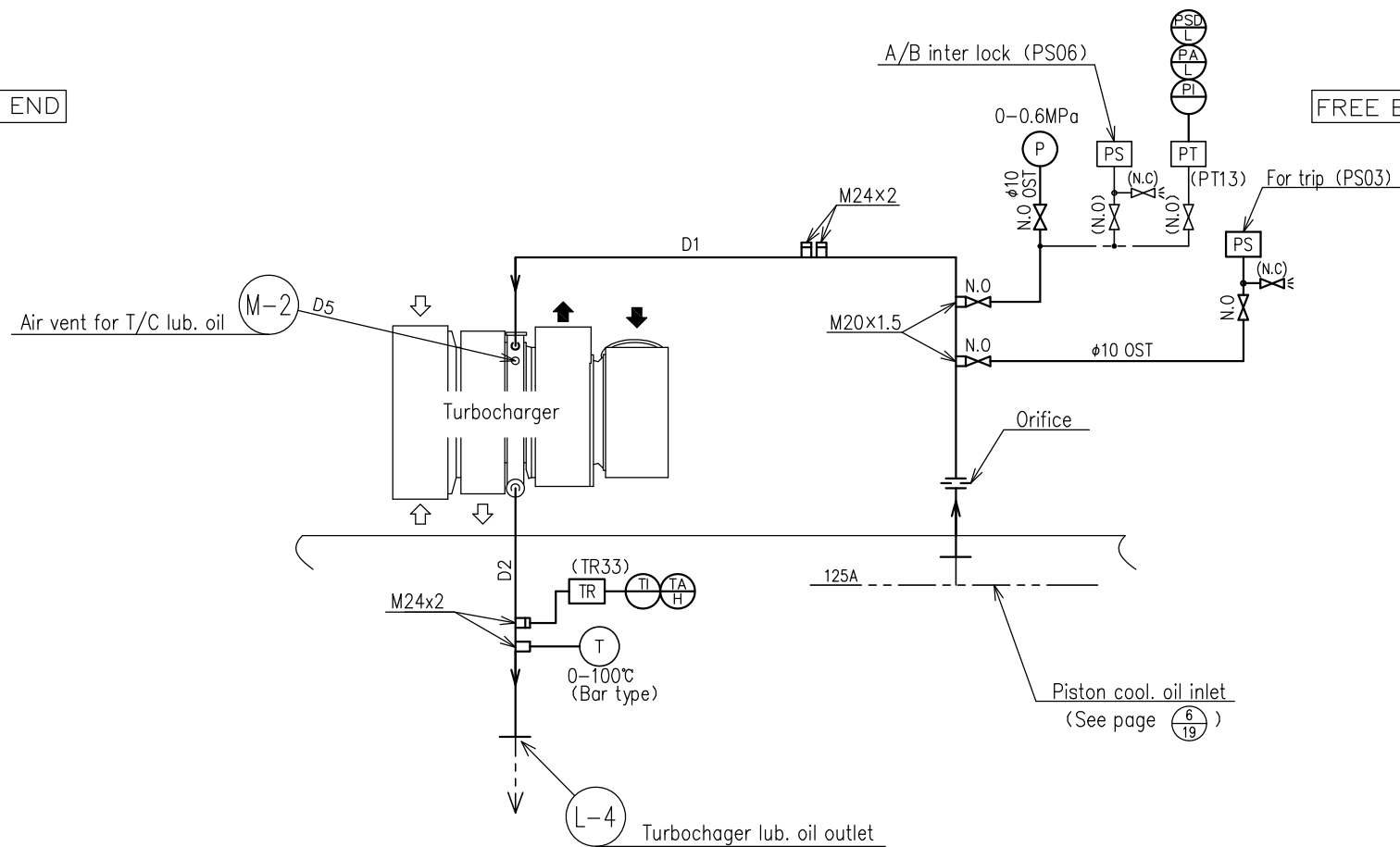

Turbocharger type	Pipe sizes		
	D1	D2	D5
MET37MB/-EGBx1	25A	50A	50A
MET42MB/-EGBx1	25A	50A	50A

View from exhaust side

6UEC42LSH-Eco-EGR

Piping diagram of turbocharger lub. oil

過給機潤滑油管線図

-D3
-D4

10
19

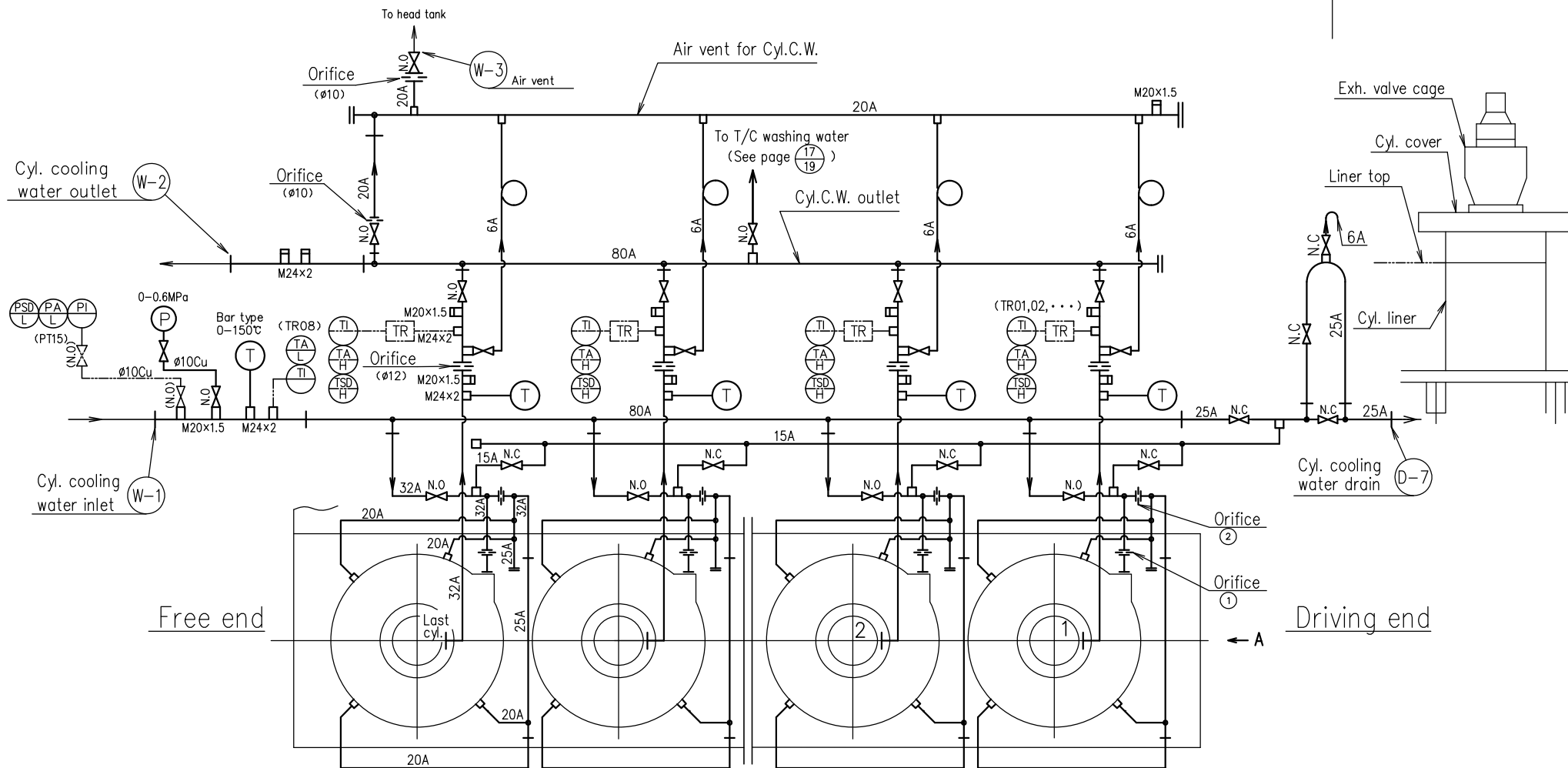

Orifice	φ (mm)
①	
②	
③	
④	
⑤	

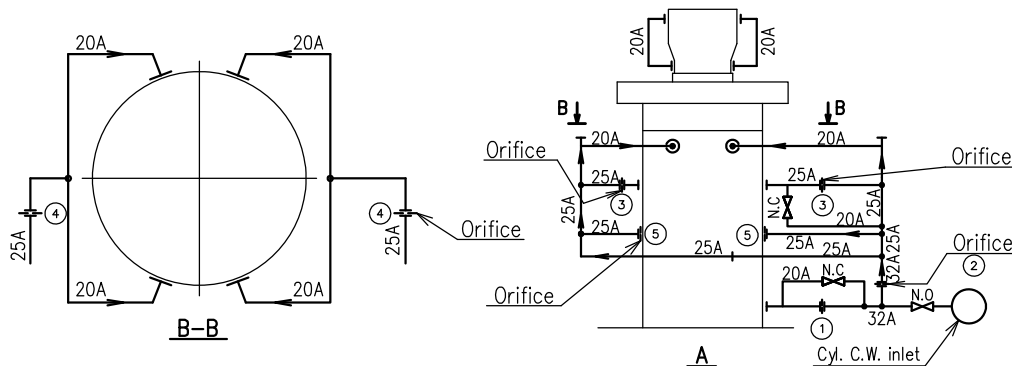

6UEC42LSH-Eco-EGR

Piping diagram of
cylinder cooling water

シリンダ冷却水管線図

-D3
-D4

FREE END

DRIVING END

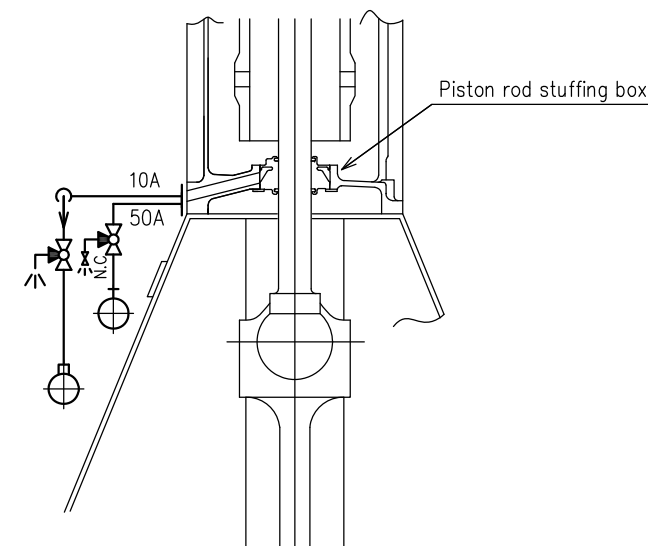
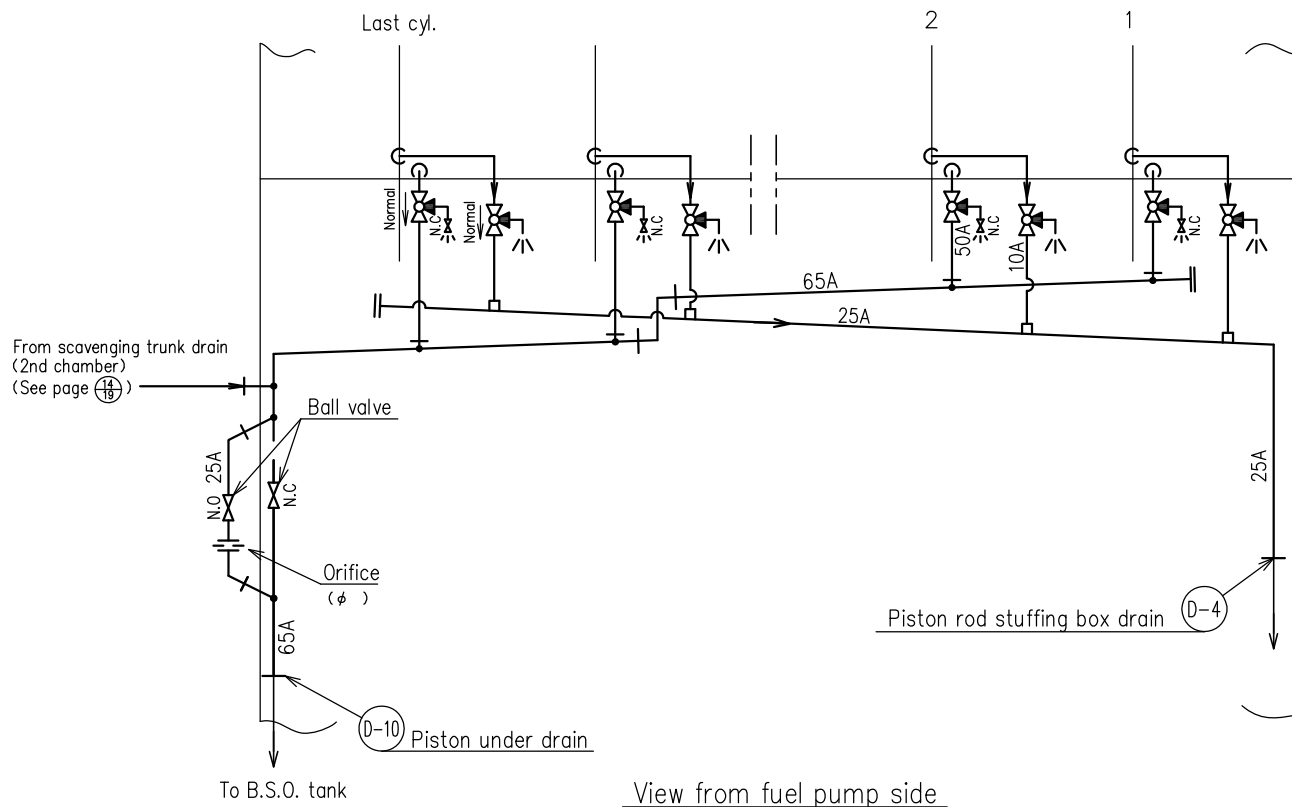

6UEC42LSH-Eco-EGR

Piping diagram of
piston rod stuffing box drain

-D3
-D4

ピストン棒パッキン箱ドレン管線図

13/19

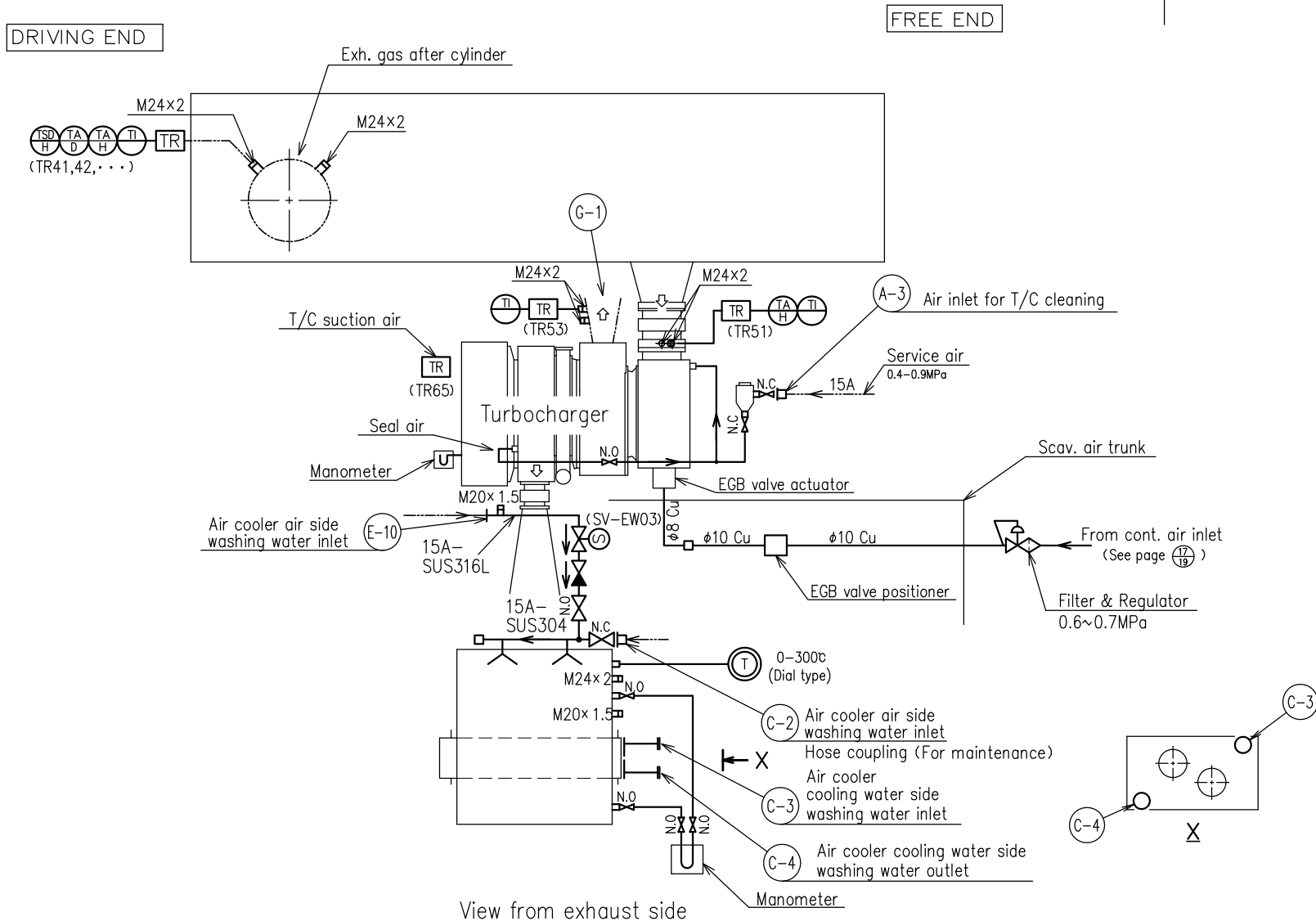

Turbocharger type
MET37MB-EGB×1
MET42MB-EGB×1

6UEC42LSH-Eco-EGR	
Piping diagram of turbocharger and air cooler washing water and exhaust gas system	-D3 -D4
過給機空気冷却器洗浄水管及び排気ガス線図	15 19

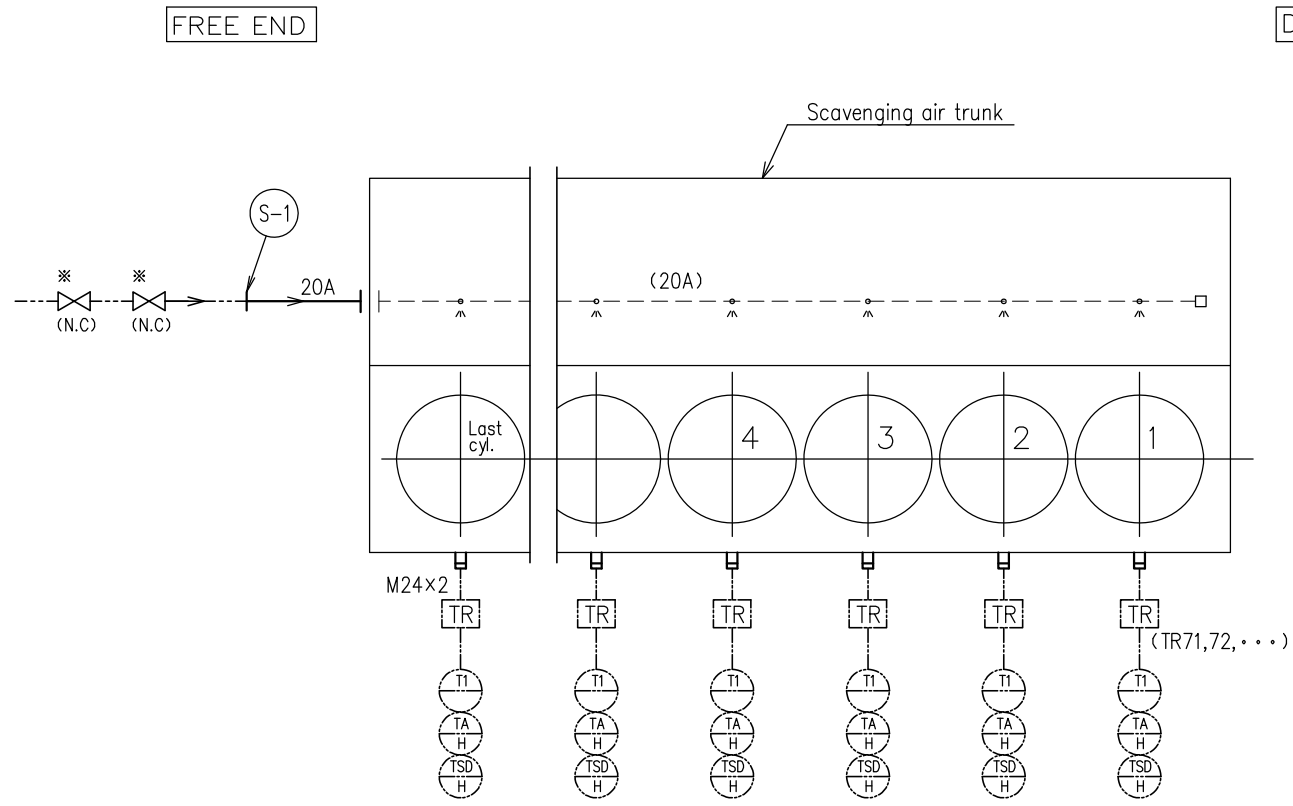

※ Supplied by shipyard.
造船所殿所掌

6UEC42LSH-Eco-EGR

Piping diagram of
fire extinguishing

掃気室火災消火装置管線図

-D3
-D4

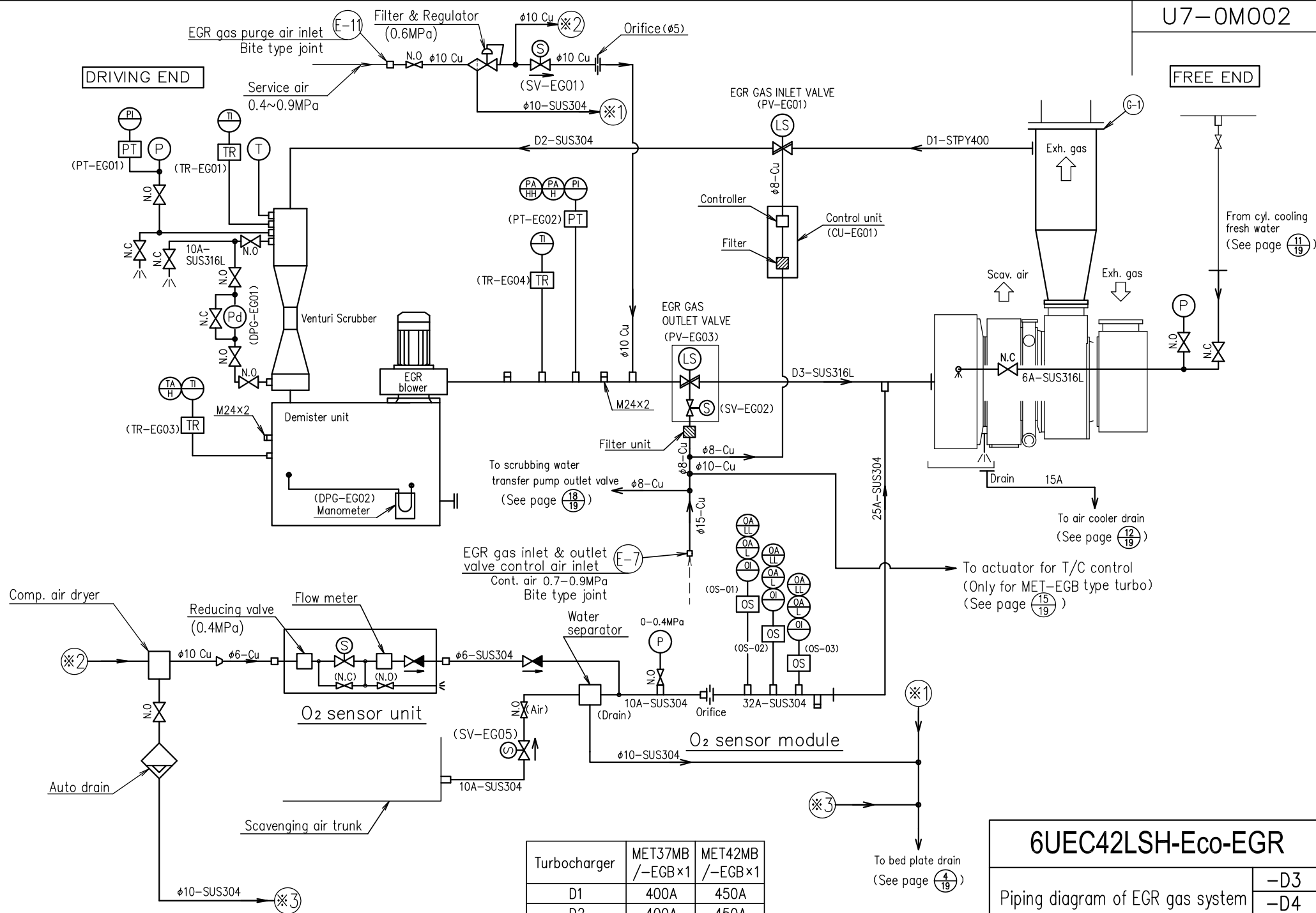

Turbocharger	MET37MB /-EGB×1	MET42MB /-EGB×1
D1	400A	450A
D2	400A	450A
D3	350A	400A

6UEC42LSH-Eco-EGR

Piping diagram of EGR gas system

EGRガス線図

-D3
-D4

(17/19)

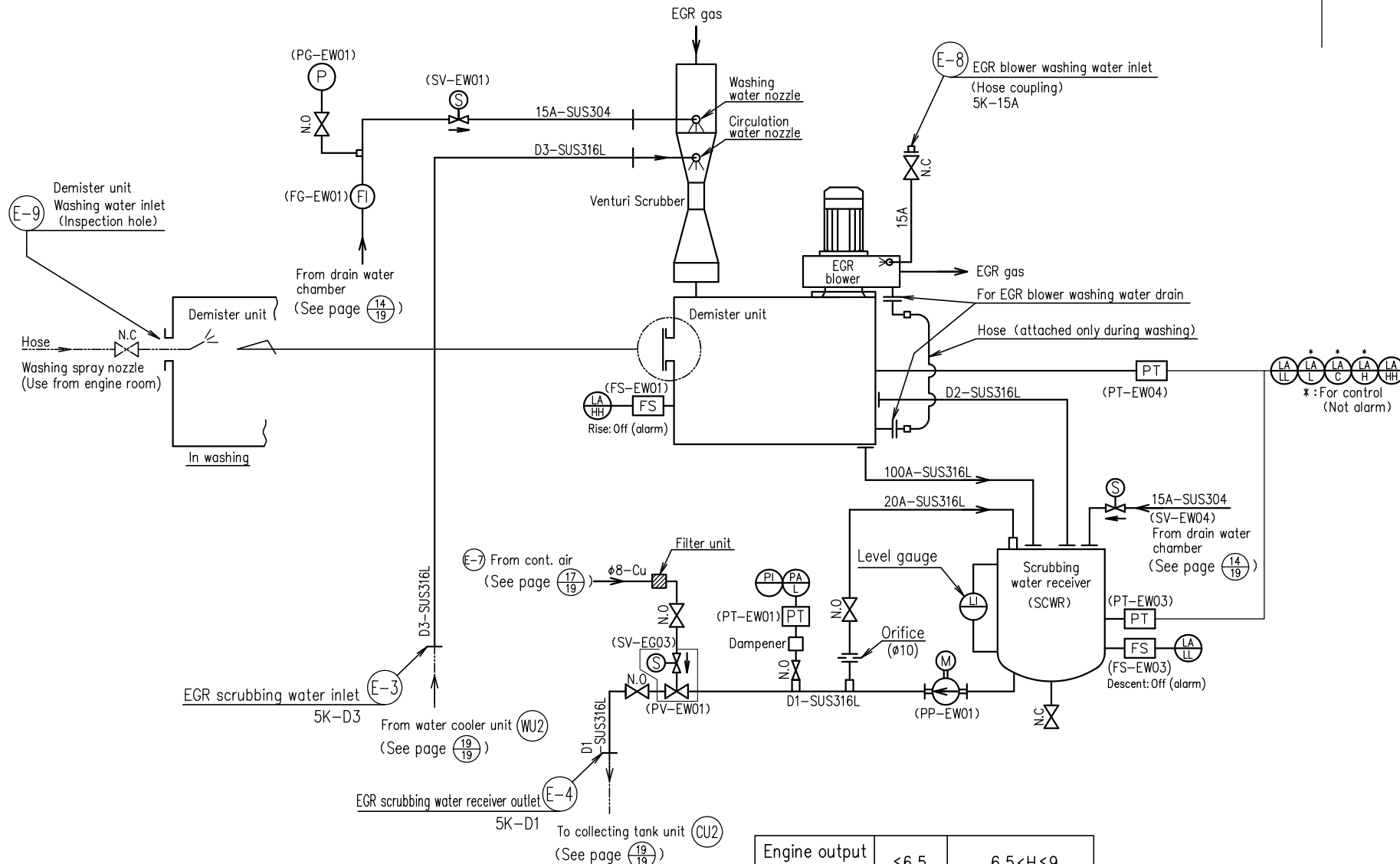

Engine output *H MW	≤6.5	6.5<H≤9
D1	50A	80A
D2	40A	40A
D3	50A	80A

* : The pipe size in the table is just example.
Please contact us as it depends on the specifications of each engine.
表の管サイズは目安です。
機関毎の仕様により異なりますのでお問い合わせください。

6UEC42LSH-Eco-EGR

Piping diagram of
EGR scrubbing water system (On engine)

-D3
-D4

EGRスクラバ水線図

18
19

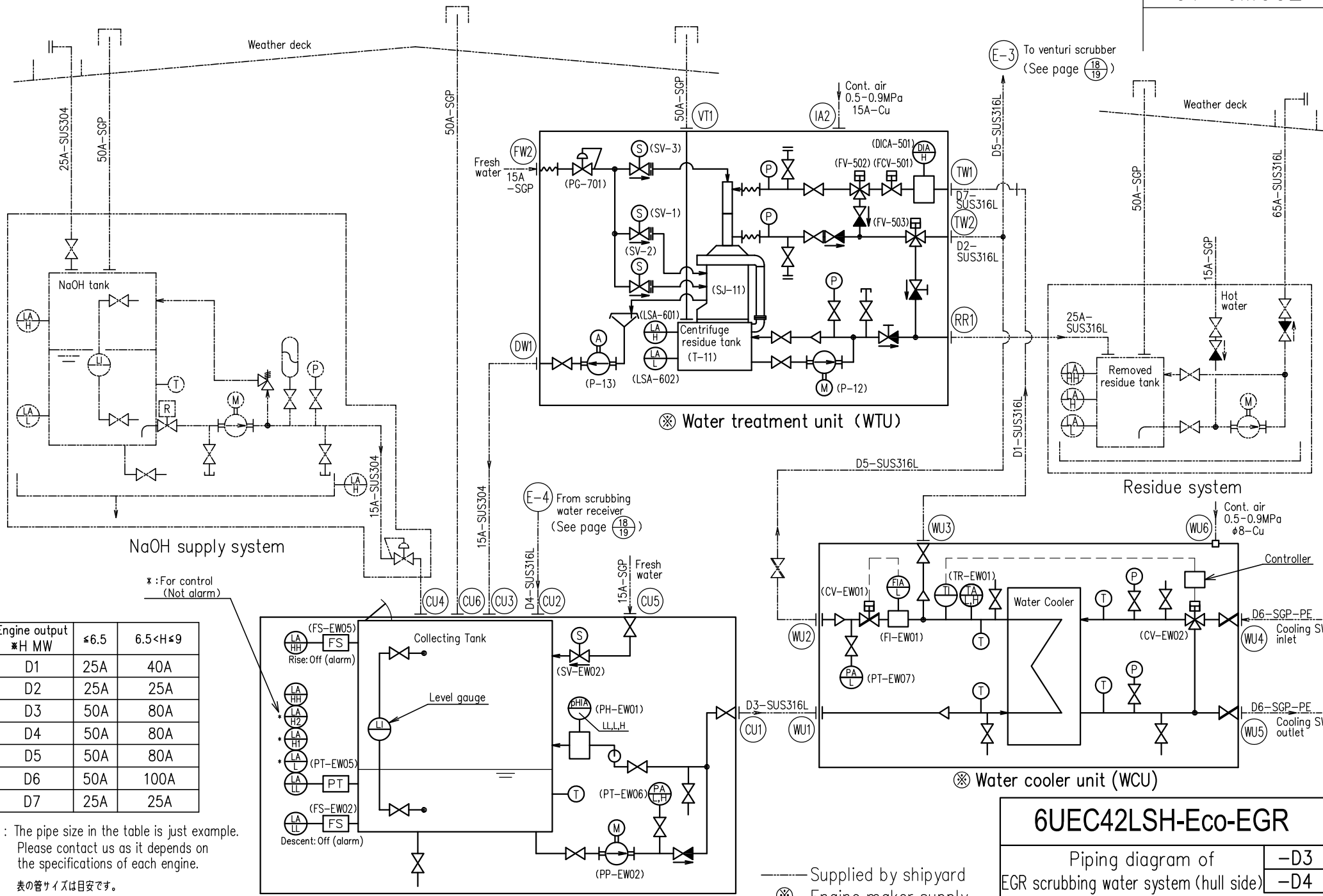

Engine output #H MW	≤6.5	6.5<H≤9
D1	25A	40A
D2	25A	25A
D3	50A	80A
D4	50A	80A
D5	50A	80A
D6	50A	100A
D7	25A	25A

* : The pipe size in the table is just example.
Please contact us as it depends on the specifications of each engine.

表の管サイズは目安です。
機関毎の仕様により異なりますのでお問い合わせください。

* : For control
(Not alarm)

— Supplied by shipyard
⊗ Engine maker supply

6UEC42LSH-Eco-EGR

Piping diagram of EGR scrubbing water system (hull side)

EGRスクラバ水線図

—D3
—D4

19/19

改訂来歴表

文 書 番 号

U7-0M002

改訂番号	項目・内容等	年月日	文 書 番 号		
			U7-0M002		
			承認	審査	担当
G	All pages have been revised. UC12756	2020-10-27	Y.Kinoshita	S.Yoshikawa	K.Amari
H	Revised page for 4/19,5-1/19,11/19,14/19,	2021-01-21	K.Imanaka	S.Yoshikawa	
	15/19,17/19,18/19,19/19. UC12809				
I	Revised page for 7/19, 8/19, 18/19, 19/19	2021-04-15	Y.Kinoshita	S.Yoshikawa	K.Amari
	UC13087				
J	Revised for page P6, 11/19, 17/19	2021-05-17	Y.Kinoshita	S.Yoshikawa	K.Amari
	UC13127				
K	Revised for page 1/19, 2/19, 3/19, 4/19	2021-06-25	Y.Kinoshita	S.Yoshikawa	K.Amari
	5-1/19, 5-2/19, 7/19, 8/19, 10/19, 11/19 12/19, 14/19, 15/19 UC13209				
L	Revised for page P7/19, 12/19, 18/19	2021-07-29	Y.Kinoshita	S.Yoshikawa	K.Amari
	UC13278				
M	Revised for page P2/19, 8/19, 12/19, 14/19	2022-05-09	Y.Kinoshita	S.Yoshikawa	K.Amari
	15/19, 17/19, 18/19, 19/19 UC13847				
N	Revised for page P19/19	2022-06-07	Y.Kinoshita	S.Yoshikawa	K.Amari
	UC13907				
O	Added page 2,3,7/19	2022-08-17	K. Edo	Y.Kinoshita S.Yoshikawa	K.Amari
	and revised whole pages. UC14005				
P	Revised for page 2, 7, 14, 15/19	2022-10-06	K. Edo	Y.Kinoshita S.Yoshikawa	K.Amari
	UC14084				
Q	Revised for page 7/19, 12/19, 15/19	2022-12-28	Y.Kinoshita	S.Yoshikawa	K.Amari
	UC14204				
R	Revised for page 2/19, 6/19, 7/19	2023-5-17	Y.Kinoshita	S.Yoshikawa	K.Amari
	UC14387				