

# 7UEC50LSH-Eco

## 諸管線図集

### PIPING DIAGRAM

Engine type	Turbocharger type	X: Apply
7UEC50LSH-Eco-C2	MET60MBx1	x
	MET53MBx1	x

前図と引換えのこと

CONTENT		REMARKS	PURCHASER	ORDER No.	DATE	Designing and Service Engineering department Marine Engine Devision		
DESCRIP TION	18 PAGE			ITEM No.	REFERENCE	APPROVED BY	M.Sugihara	
FIGURE	5 SHEET						CHECKED BY	K.Edo
TOTAL	25 PAGE						DESIGNED BY	S.Yoshikawa
PREVIOUS DRAWING U7-0K001					DRAWN BY	T.Tanaka		
					ISSUE			
					DATE	2013-10-16		
FACTORY	テ 設 外		控	DWG. No.		Rev. No.		
				U7-0K008		F		

REVISION CAREER		DWG NO.			
		U7-0K008			
REV.NO.	DESCRIPTION	DATE	APPROVED	CHECKED	DESIGNED
A	Revised page for 12/16 ----- -----	2013.12.3	for K.Edo	K.Edo	S.Yoshikawa T.Tanaka
B	Revised page for 6/16,7/16 ----- -----	2014.01.21	for S.Yoshikawa	S.Yoshikawa	T.Tanaka
C	Revised page for 1/16~16/16 ----- K.Fuji	2015.03.03	K.Edo	A.Aota	S.Yoshikawa T.Kakimoto
D	Revised page for 7/16 ----- UC9998	2015.03.17	K.Edo	A.Aota	N.Asada
E	Revised page for 1-1/16,4/16~7/16 ----- UC10512	2016.07.27	K.Edo	S.Yoshikawa	T.Hamanishi
F	Revised page for 1-1/16,1-2/16,13/16,14/16 ----- UC10747	2016.11.14	K.Edo	S.Yoshikawa	T.Hamanishi
	----- ----- ----- ----- ----- ----- ----- ----- ----- -----				











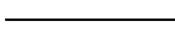

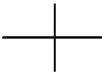
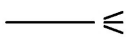
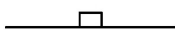
# 諸管線図名称

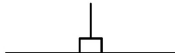
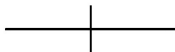
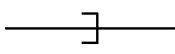
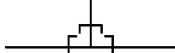

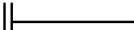
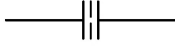









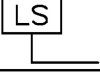

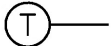
Name of piping diagram

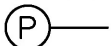
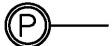
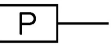

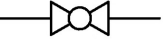



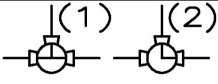
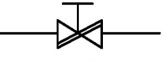



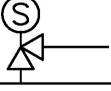

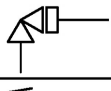
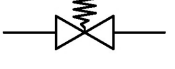
U7-OK008	①-1 16	Starting air 始動空気管線図
” ”	①-2 16	Exh.valve spring air 排気弁エアースプリング管線図
” ”	② 16	Fuel oil 燃料油管線図
” ”	③ 16	Fuel oil steam 燃料油加熱蒸気管線図
” ”	④ 16	Lubricating oil 潤滑油管線図
” ”	⑤ 16	Axial damper oil 縦振動ダンパー油管線図
” ”	⑥ 16	Piston cooling oil ピストン冷却油管線図
” ”	⑦ 16	Hydraulic supply oil (Common system) 油圧作動油管線図 (共油系統)
” ”	⑧ 16	Actuator oil for exhaust valve 排気弁駆動油管線図
” ”	⑨ 16	Cylinder lubricating oil for A-ECL system シリンダ注油管線図 (A-ECLシステム)
” ”	⑩ 16	Turbocharger lubricating oil 過給機潤滑油管線図
” ”	⑪-1 16	Cylinder cooling water (Uniflow cooling) シリンダ冷却水管線図 (ユニフロー冷却)
” ”	⑪-2 16	Cylinder cooling water (Loop cooling) シリンダ冷却水管線図 (ループ冷却)
” ”	⑫ 16	Air cooler cooling water 空気冷却器冷却水管線図
” ”	⑬ 16	Piston rod stuffing box drain ピストン棒パッキン箱ドレン管線図
” ”	⑭ 16	Scavenging air trunk drain 掃気トランクドレン管線図
” ”	⑮ 16	Turbocharger and air cooler washing water and exhaust gas system 過給機空気冷却器洗浄水管及び排気ガス線図
” ”	⑯ 16	Fire extinguishing 掃気室火災消火装置管線図

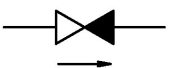
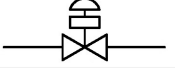
## SYMBOLS FOR MAIN ENGINE PIPING DIAGRAM

## 主 機 関 諸 管 線 図 記 号

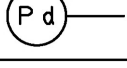
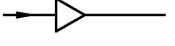
SYMBOLS 記 号	NAME	名 称	REMARKS 備 考
	Nominal inner diameter	称 呼 口 径	
	Crossing pipes, connected	連 結 管	
	Crossing Pipes, not connected	不 連 結 管	
	To bilge	ビ ル ジ ヘ	
	Boss	ボ ス	
	Boss and plug	プ ラ グ 付 ボ ス	
	Joint, bossed	ボ ス 継 手	
	Joint, flanged	フ ラ ン ジ 継 手	
	Joint, screwed	ね じ 継 手	
	Tee joint, screwed	T 形 ね じ 継 手	
	Spectacle flange	め が ね フ ラ ン ジ	
	Blind flange	閉 止 フ ラ ン ジ	
	Orifice	オ リ フ ィ ス	
	Flexible pipe	フ レ キ シ ブ ル パ イ プ	
	Hopper	ホ ッ パ ー	
	Hopper with cover	ふ た 付 ホ ッ パ ー	
	Air pipe	空 気 抜 管	
	Loop seal pipe siphon	ル ー プ シ ー ル パ イ プ サ イ フ ォ ン	
	Siphon	サ イ フ ォ ン	

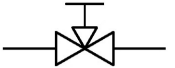
SYMBOLS 記号	NAME	名 称	REMARKS 備 考
-----	Elect. cable	電 気 配 線	
-----	Outfit line (to be delivered by yard)	造 船 所 所 掌 配 管	
-----	Insulation lagging	ラギング	
	Pressure switch	圧 力 ス イ ッ チ	
	Temperature switch	温 度 ス イ ッ チ	
	Float switch	フ ロ ー ト ス イ ッ チ	
	Limit switch	リ ミ ッ ト ス イ ッ チ	
	LCD indication		
Bar Type 	Thermometer	温 度 計	
Dial Type 			
Engine side 	Pressure gauge	圧 力 計	
on Gauge board 			
Engine cont. room 			
	U Tube manometer	U字管式圧力計	
	Cock	コ ッ ク	
	Stop valve	止 め 弁	Globe valve 玉 形 弁
			Angle valve ア ン グ ル 弁
	Thermometer pocket	温 度 計 座 (ポケット付)	
	Three-way cock	三 方 コ ッ ク	(1) T形 (T-PORT) (2) L形 (L-PORT)
	Butterfly valve	バ タ フ ラ イ 弁	
	Solenoid operated valve	電 磁 弁	

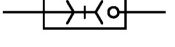
SYMBOLS 記号	NAME	名 称	REMARKS 備 考
	Solenoid operated valve (angle)	電 磁 弁	
	Gate valve	仕 切 弁	
	Hose valve	ホ - ス 弁	
	Hose valve (angle)	ホ - ス 弁 (アングル)	
	Safety valve	安 全 弁	
	Swing check valve	スイング逆止弁	
	Swing check valve (angle)	スイング逆止弁 (アングル)	
	Lift check valve	リフト逆止弁	
	Diaphragm operated valve (with positioner & handle)	ダイヤフラム操作弁 (ポ ジショナ及びハンドル付)	
	Sight glass	サイトグラス	
	Simplex strainer	単 式 コ シ	
	Duplex strainer	復 式 コ シ	
	Y type strainer	Y形ストレーナ	
	Differential pressure gauge	差 圧 計	
	Reducer	レ ジ ュ - サ	
	Hose coupling	ホ - ス 継 手	
	Regulating valve	自 動 調 整 弁	
	Ball valve	ボ - ル 弁	
	Self - seal joint	セルフシール継手	

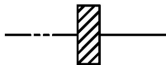
SYMBOLS 記号	NAME	名称	REMARKS 備考
	Remotely Indicated	遠隔指示計	
PI	Pressure Indication	圧力指示	
PA	Pressure alarm	圧力警報	
TI	Temperature Indication	温度指示	
TA	Temperature alarm	温度警報	
LI	Level Indication	液面指示	
LA	Oil or water level alarm	液面警報	
FI	Flow Indication	流れ指示	
FA	Flow alarm	流れ警報	
DPA	Differential pressure alarm	差圧警報	
H	High (high press., high temp., high level)	高圧, 高温, 高液面	A(警報)のつぎにだけ用いる。 使用例 TAH TAL
L	Low (low press., low temp., high level)	低圧, 低温, 低液面	
PM	pressure Indication on VDU	圧力: VDUに指示	
TM	Temperature Indication on VDU	温度: VDUに指示	
PR	Pressure recording	圧力記録	
TR	Temperature recording	温度記録	
ASD	Auto slow down	自動減速	
	Terminal connection	ターミナルコネクション	

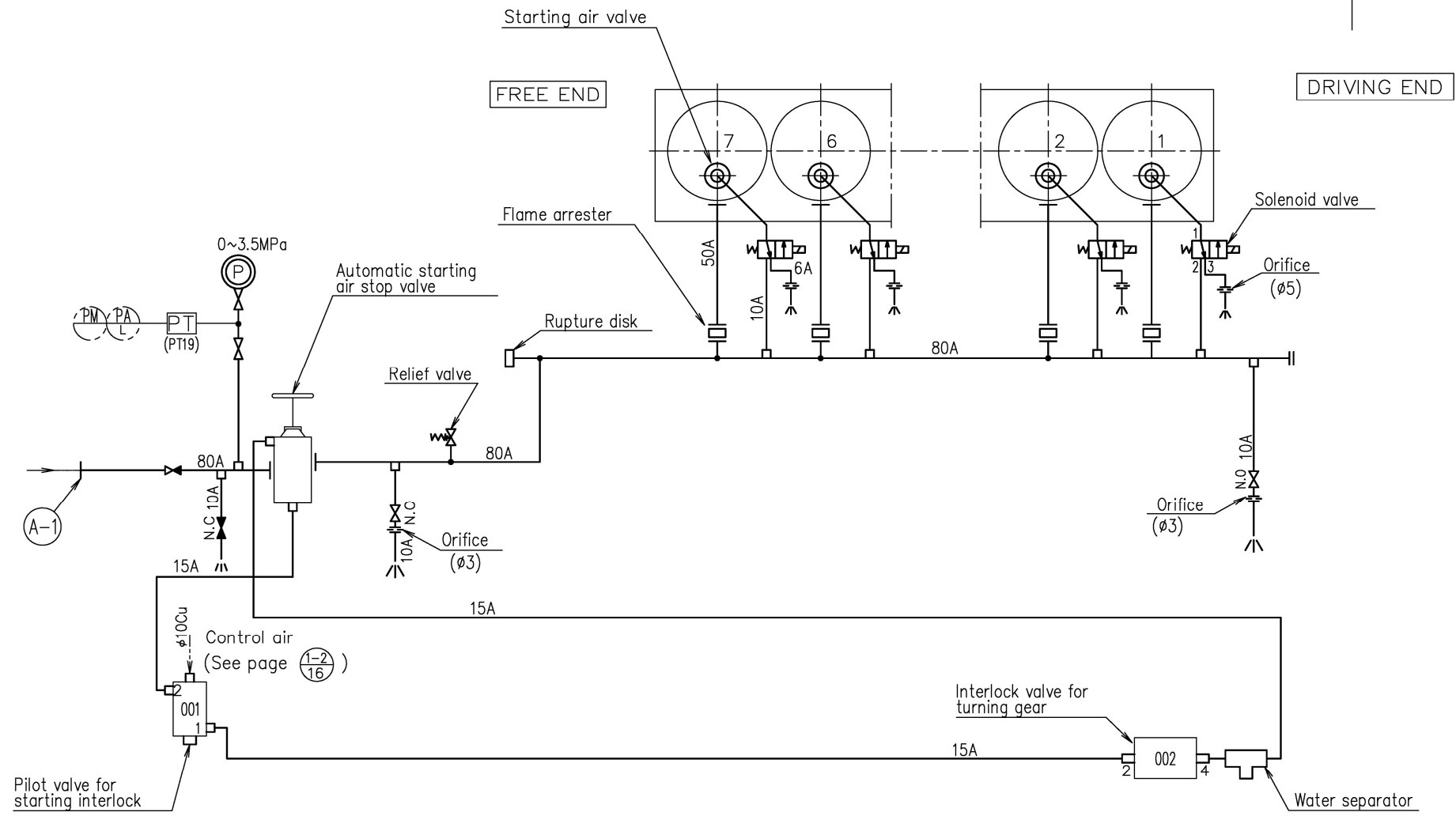

**7UEC50LSH-Eco**

Piping diagram of starting air  
始動空氣管線圖



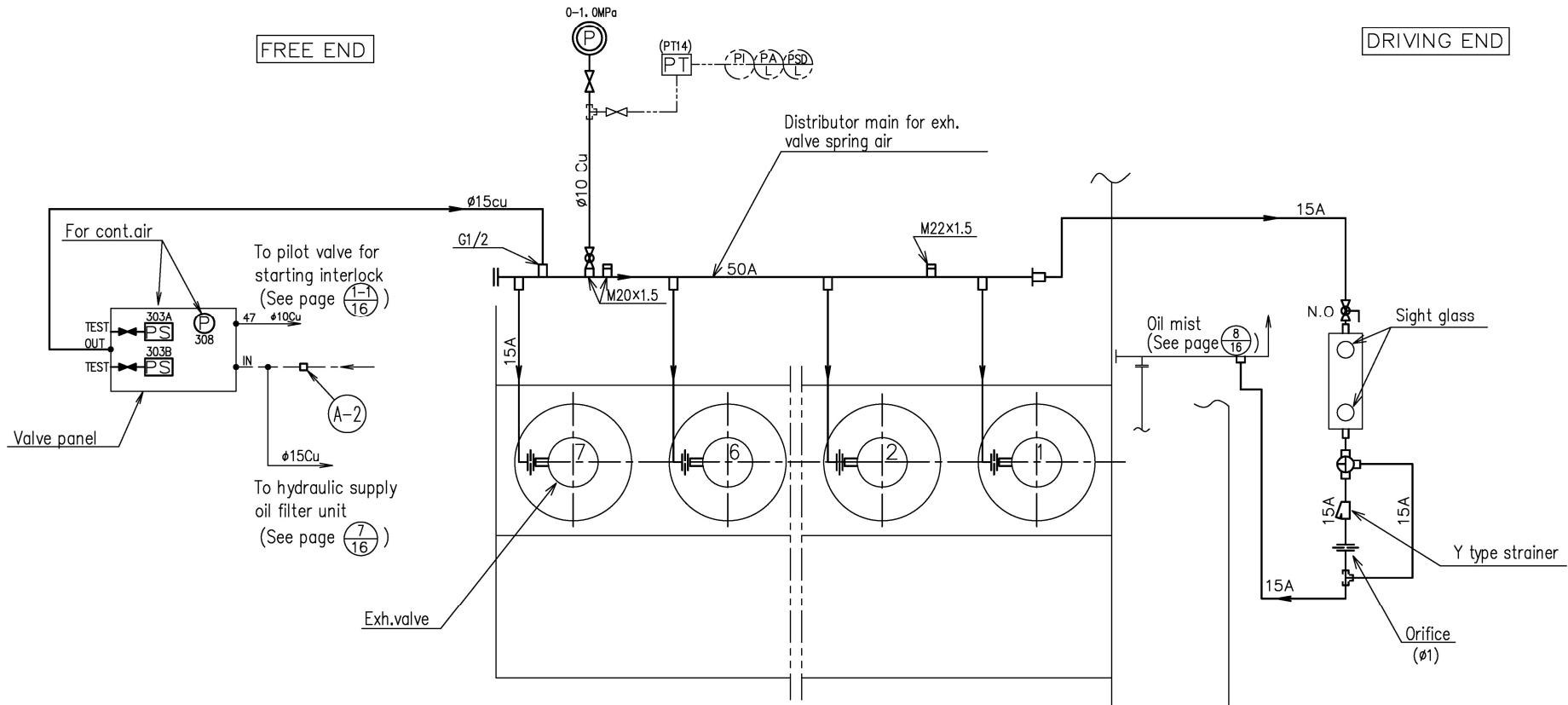

**7UEC50LSH-Eco**

Piping diagram of  
exh. valve spring air

排気弁エアースプリング管線図 1-2 A △

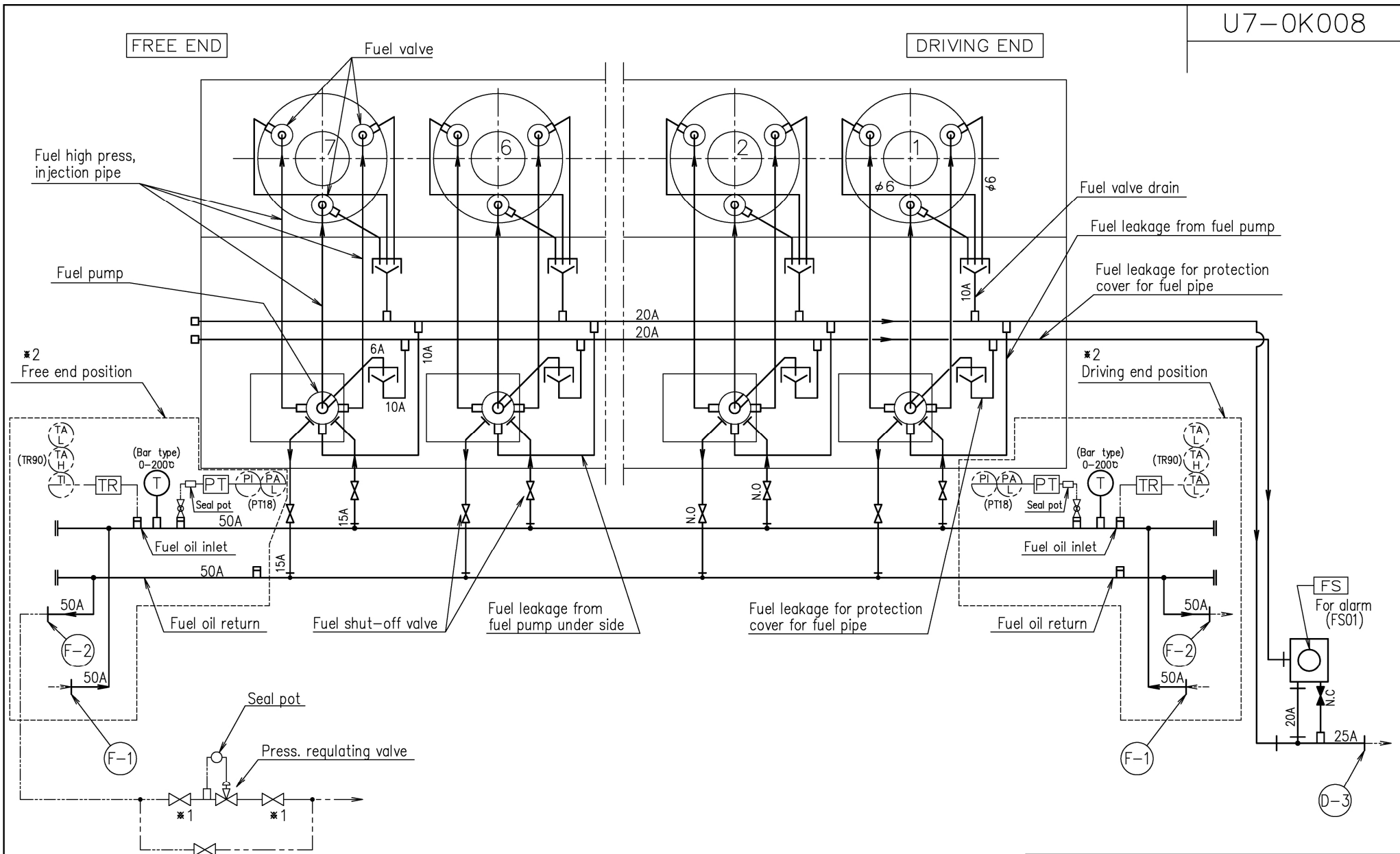

- ※1 Supplied by shipyard.  
造船所殿所掌
- ※2 That of selecting one of the other.  
どちらか一方を選択のこと。

**7UEC50LSH-Eco**

Piping diagram of  
fuel oil  
燃料油管線図

2/16

FREE END

DRIVING END

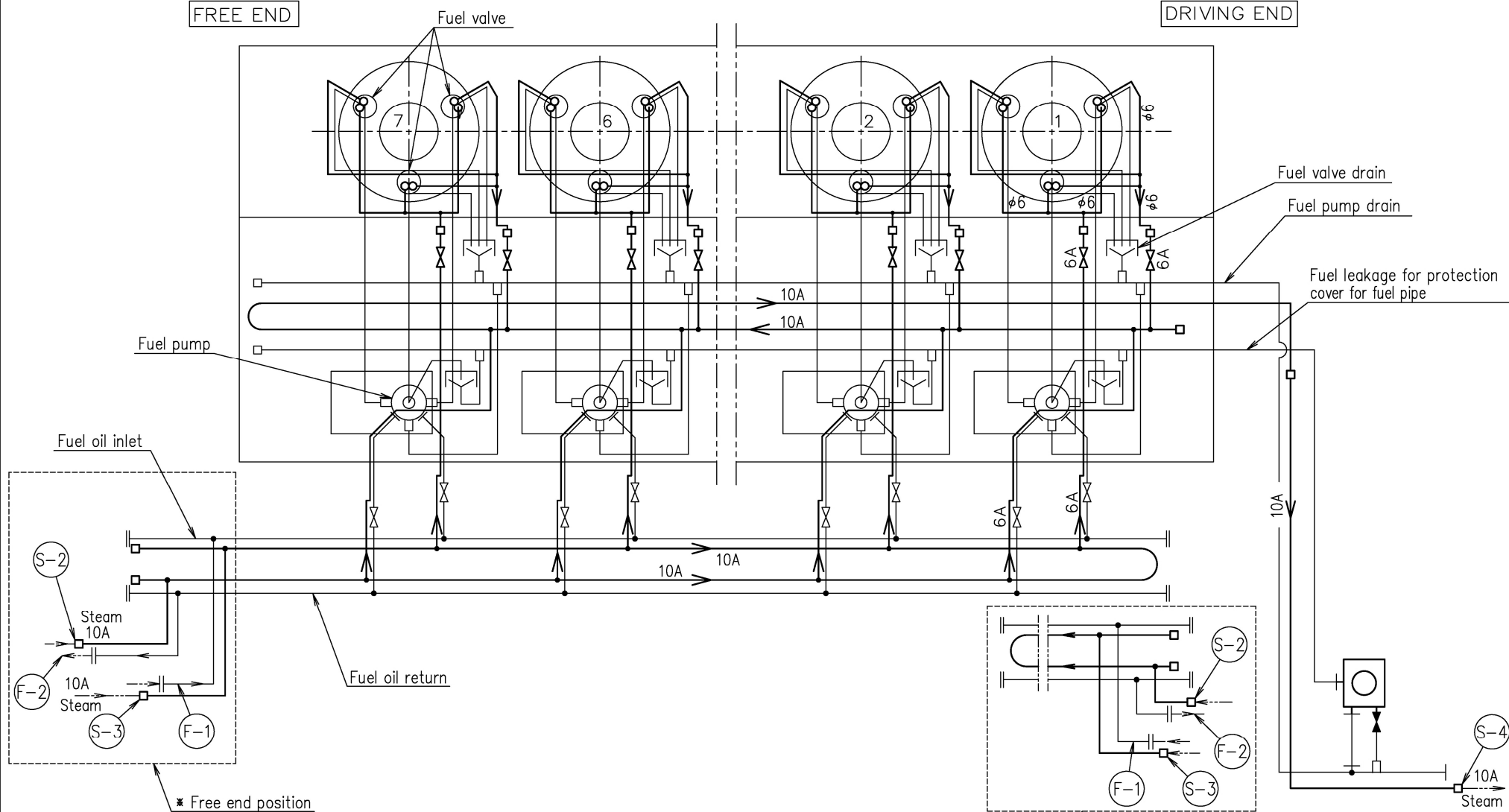

**7UEC50LSH-Eco**

Piping diagram of  
fuel oil steam

燃料油加熱蒸気管線図

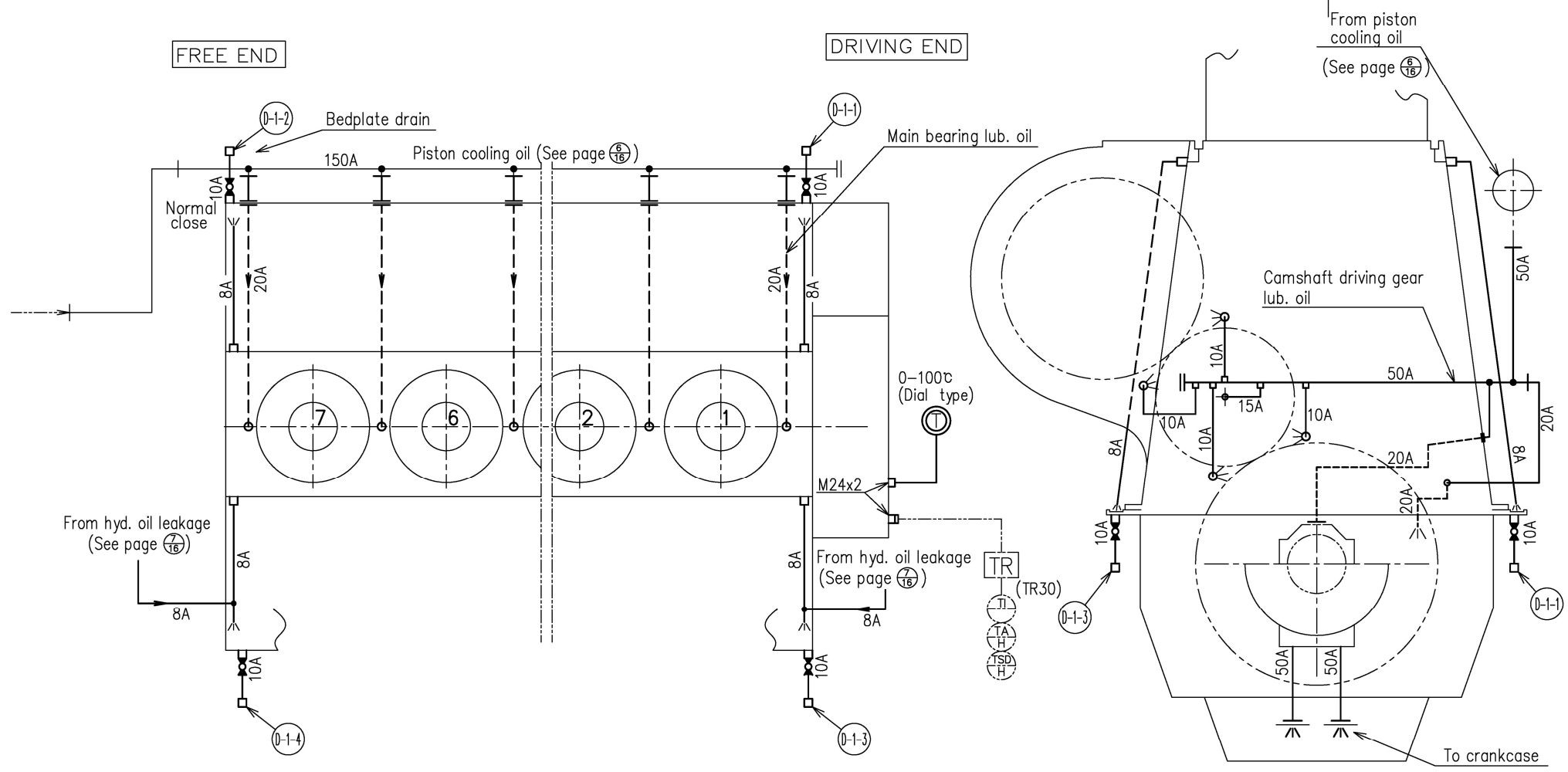

View from driving end

# 7UEC50LSH-Eco

Piping diagram of lubricating oil  
 潤滑油管線図

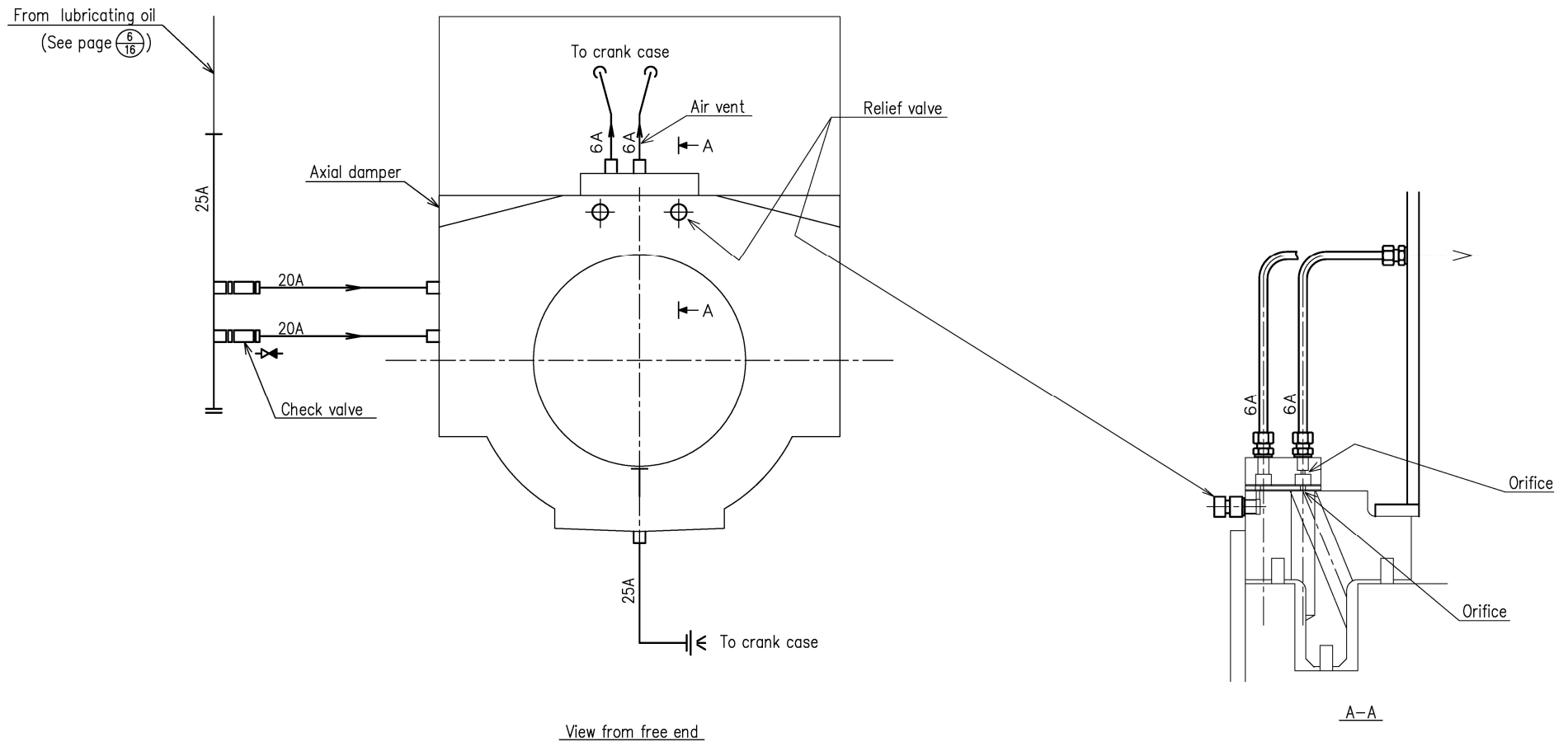

### 7UEC50LSH-Eco

Piping diagram of  
axial damper oil  
縦振動ダンパー油管線図

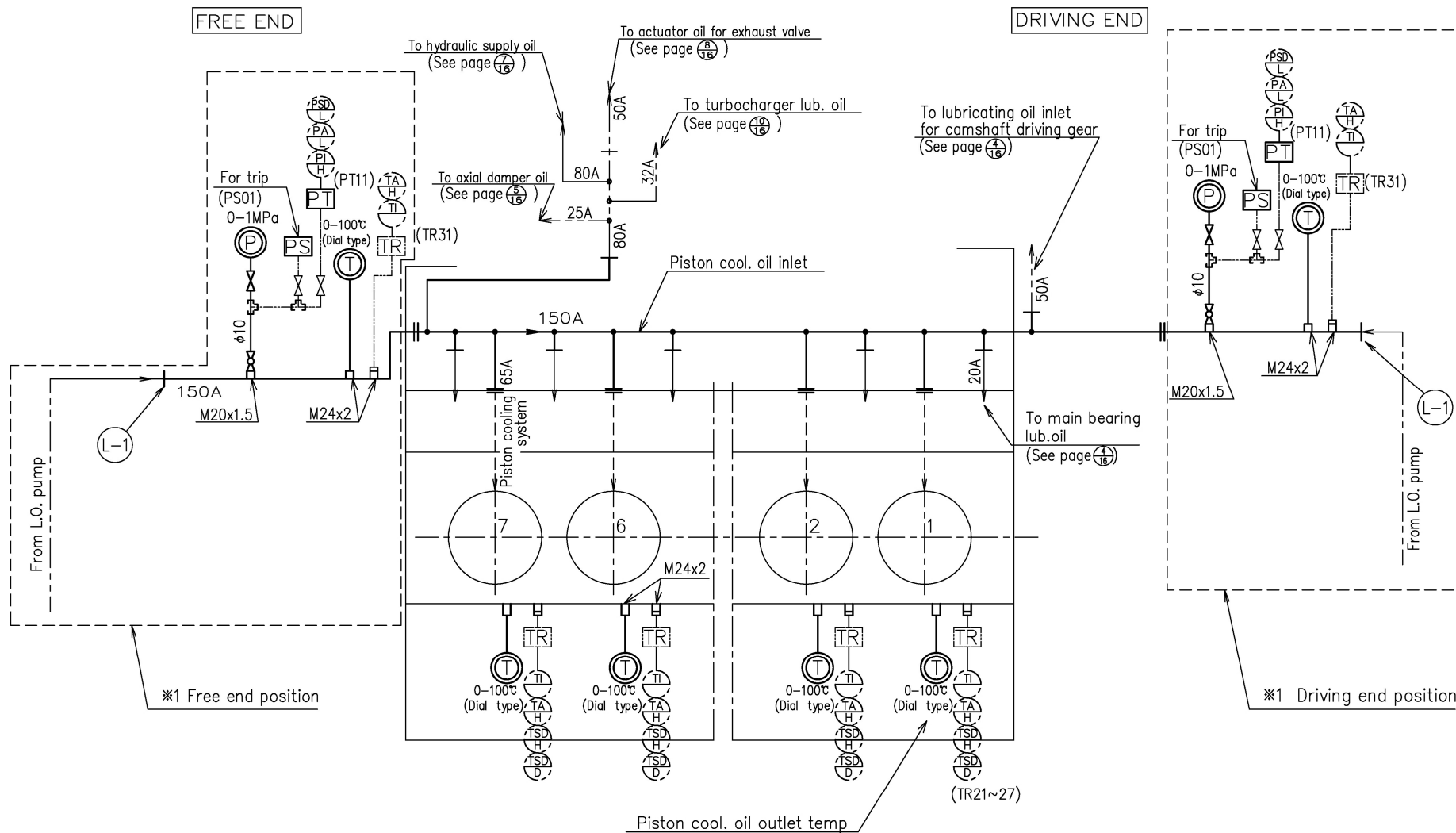

※1 Free end position

※1 Driving end position

※1 That of selecting the one of the other.  
 どちらか一方を選択のこと。

### 7UEC50LSH-Eco

Piping diagram of  
 piston cooling oil  
 ピストン冷却油管線図

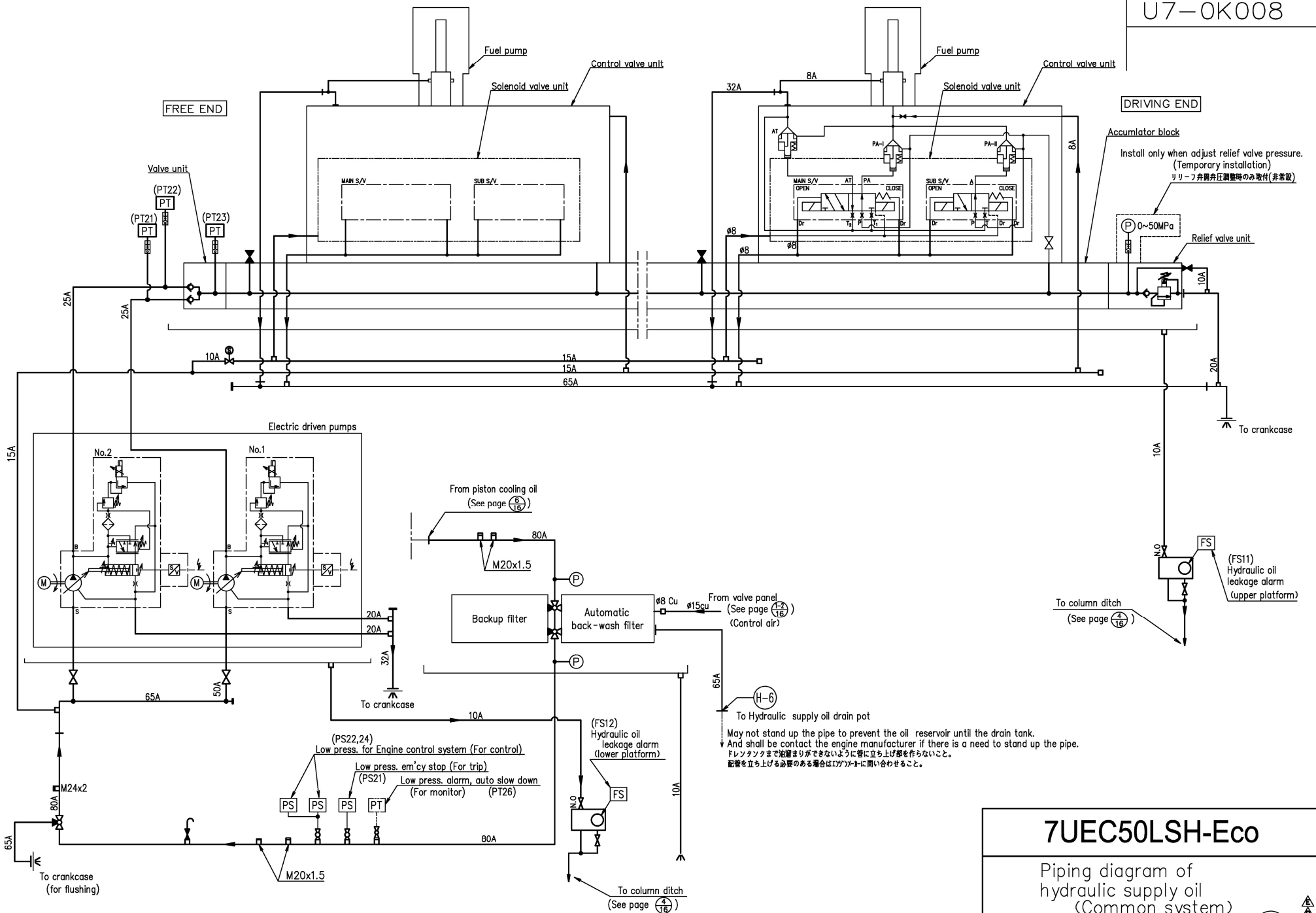

# 7UEC50LSH-Eco

Piping diagram of hydraulic supply oil (Common system)

油圧作動油管線図(共油系統) 7/16



FREE END

DRIVING END

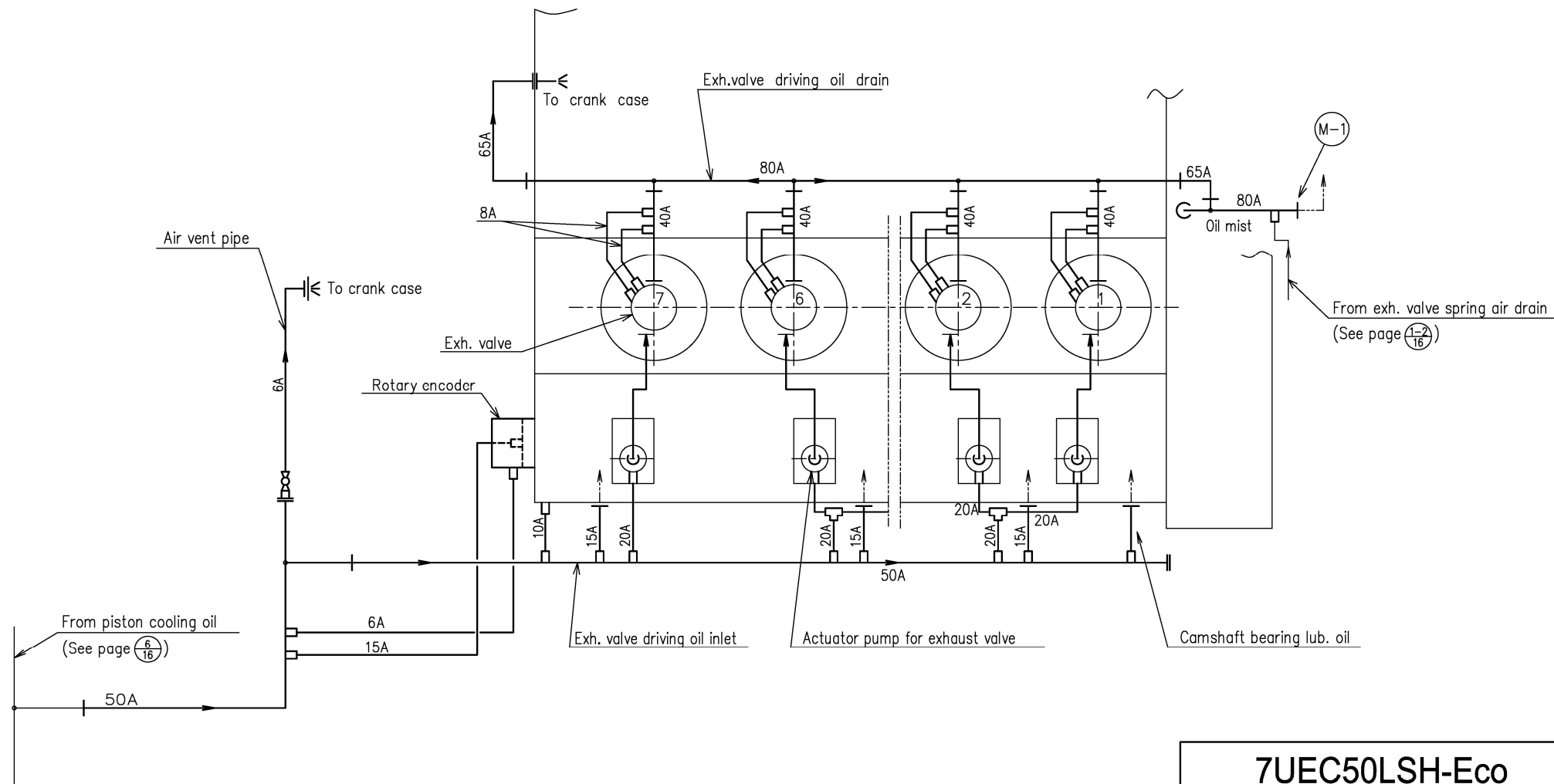

### 7UEC50LSH-Eco

Piping diagram of actuator oil for exhaust valve

排気弁駆動油管線図



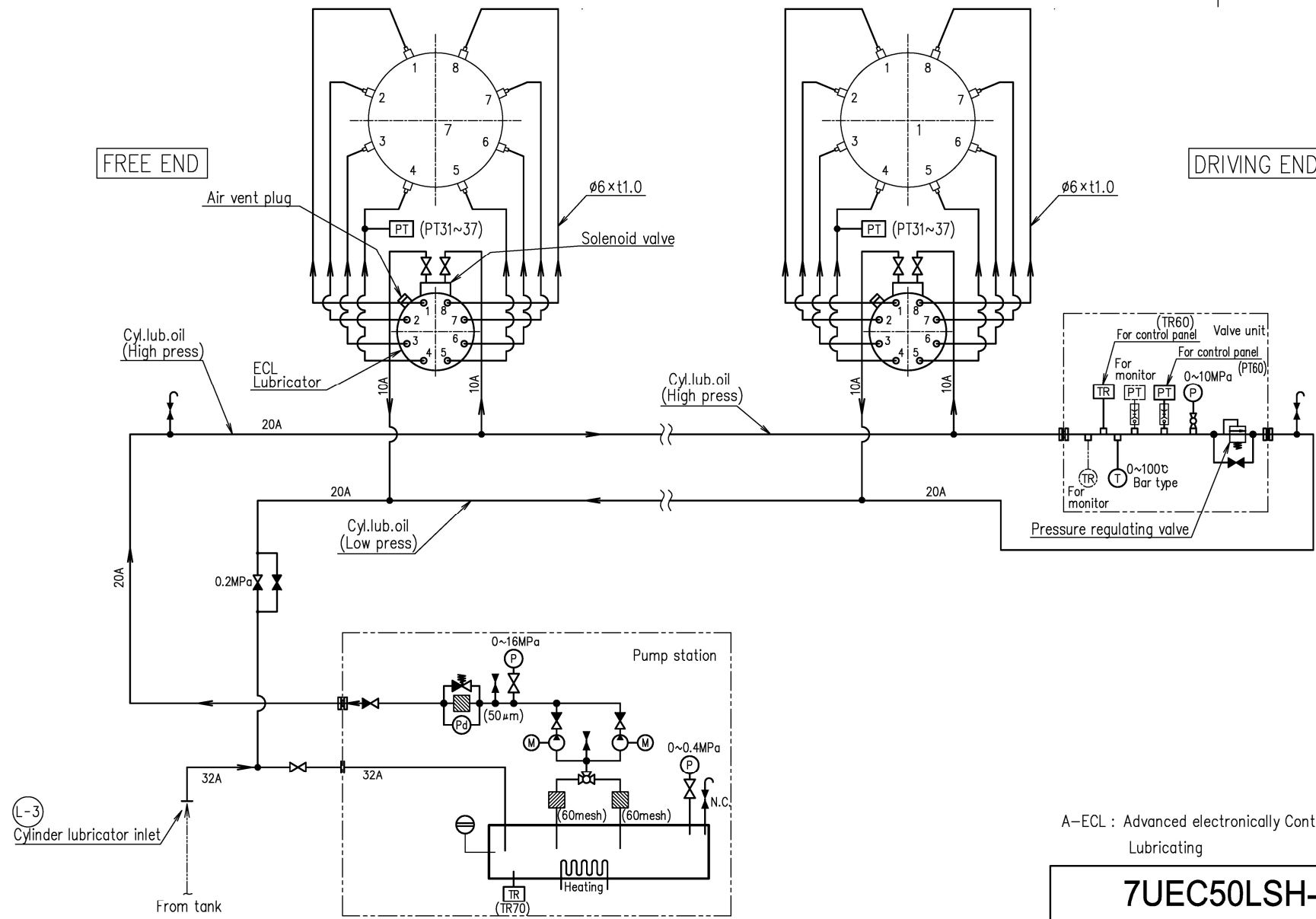

A-ECL : Advanced electronically Controlled cylinder Lubricating

## 7UEC50LSH-Eco

Piping diagram of cylinder lubricating oil for A-ECL system  
 シリンダ注油管線図 (A-ECL用)

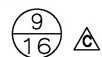

DRIVING END

FREE END

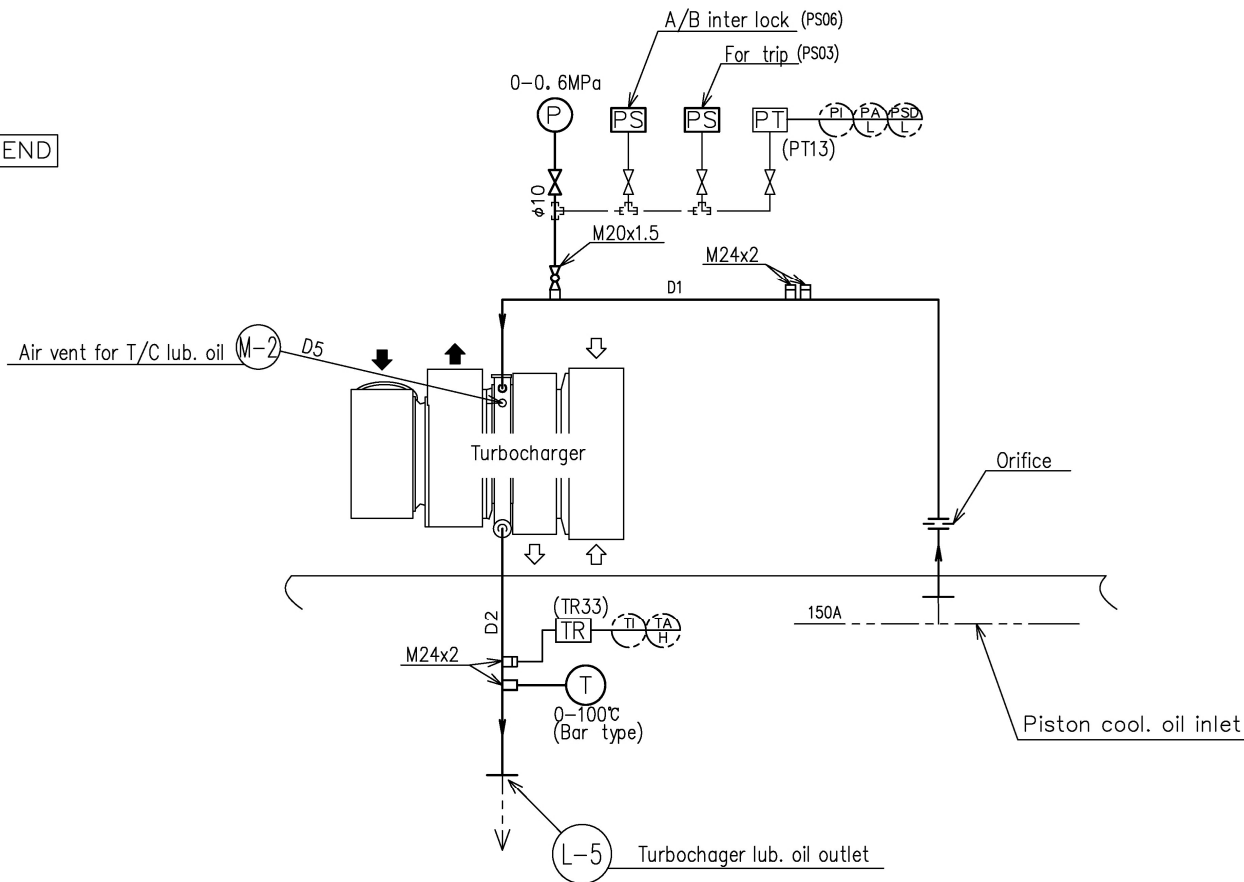

View from exhaust side

Turbocharger type	Pipe sizes		
	D1	D2	D5
MET53MB×1	32A	65A	65A
MET60MB×1	32A	80A	80A

## 7UEC50LSH-Eco

Piping diagram of  
Turbocharger lubricating oil

過給機潤滑油管線図



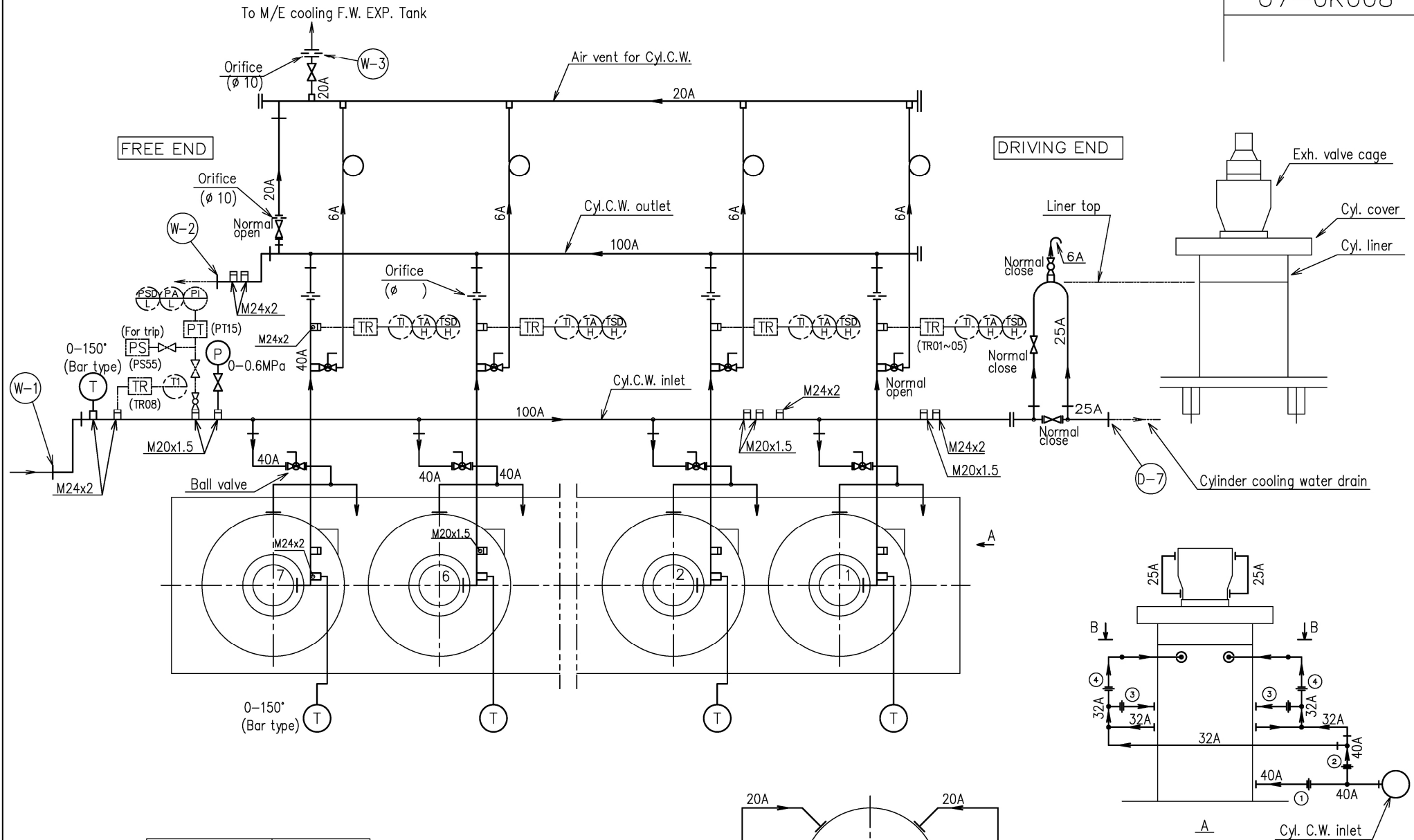

Orifice	φ (mm)
①	
②	
③	
④	

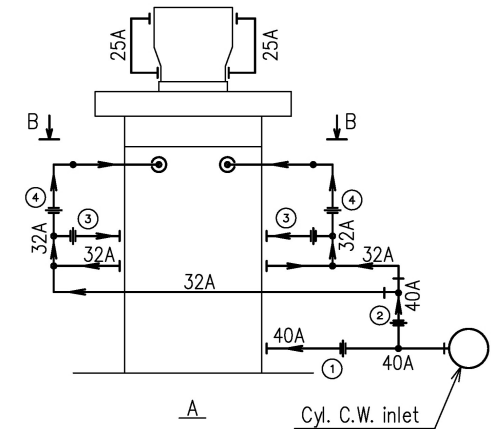
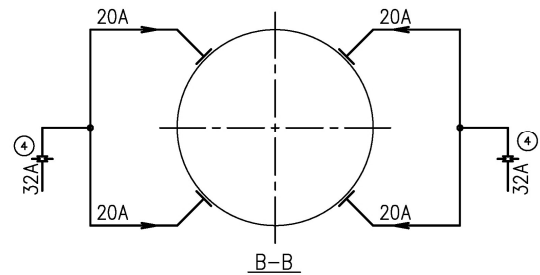

**7UEC50LSH-Eco**  
 Piping diagram of cylinder cooling water (Uniflow cooling)  
 シリンダ冷却水管線図 (ユニフロー冷却) 11-1  
16

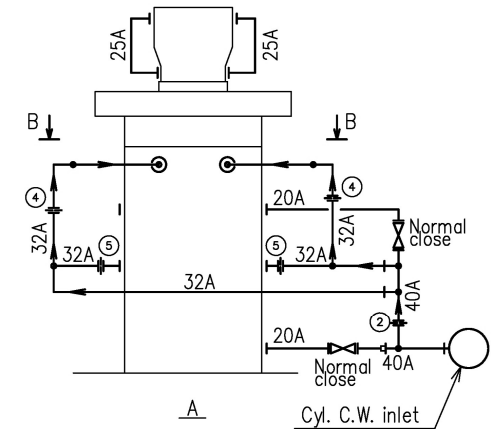
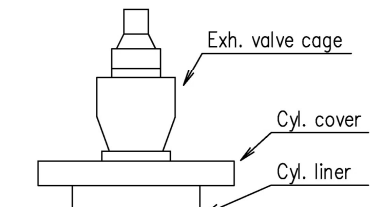
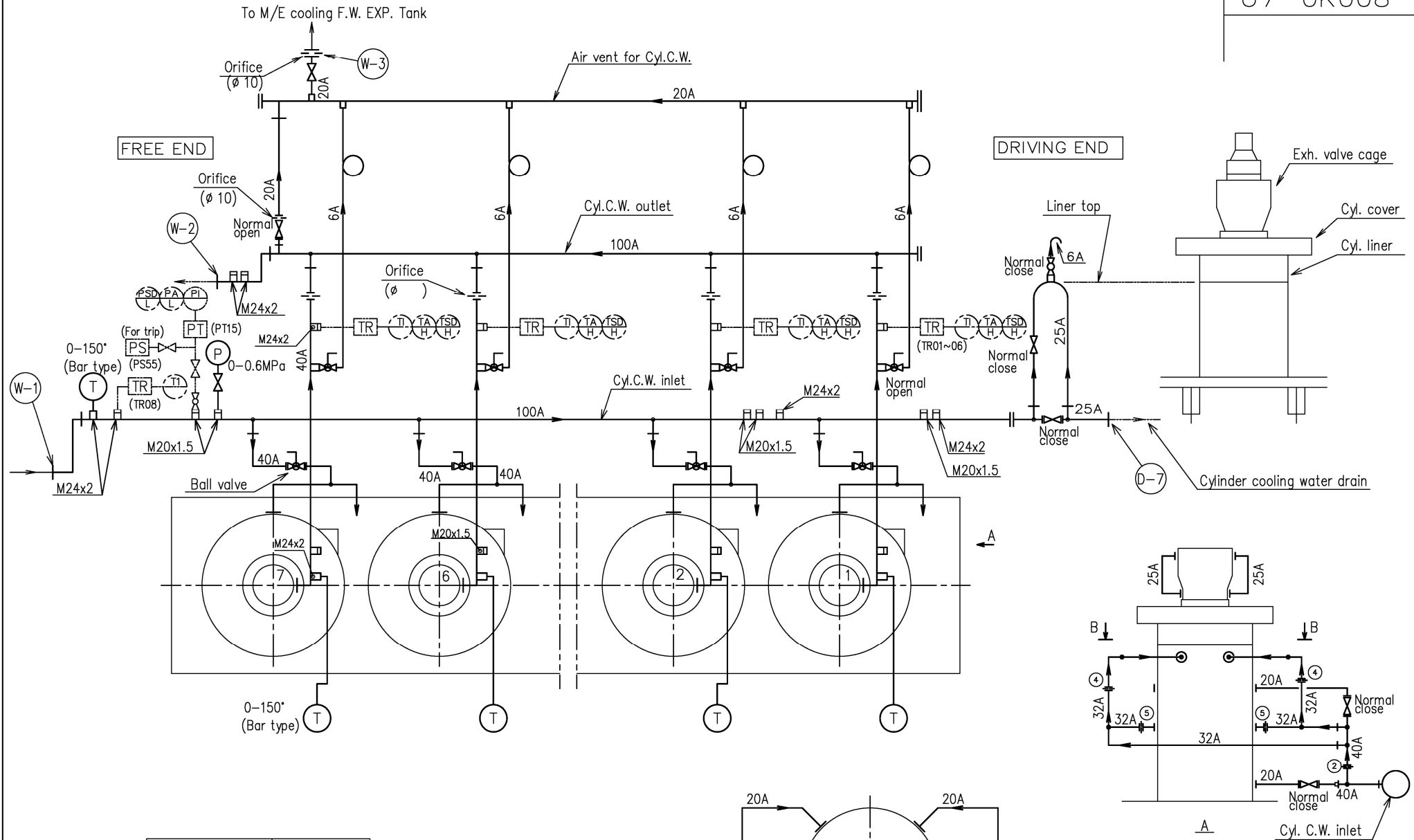

Orifice	φ (mm)
②	φ49
④	φ43
⑤	φ43

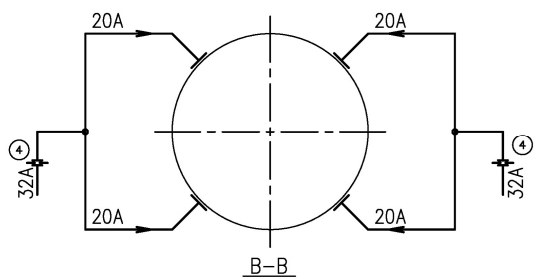

**7UEC50LSH-Eco**  
 Piping diagram of cylinder cooling water (Loop cooling)  
 シリンダ冷却水管線図 (ループ冷却) 11-2/16

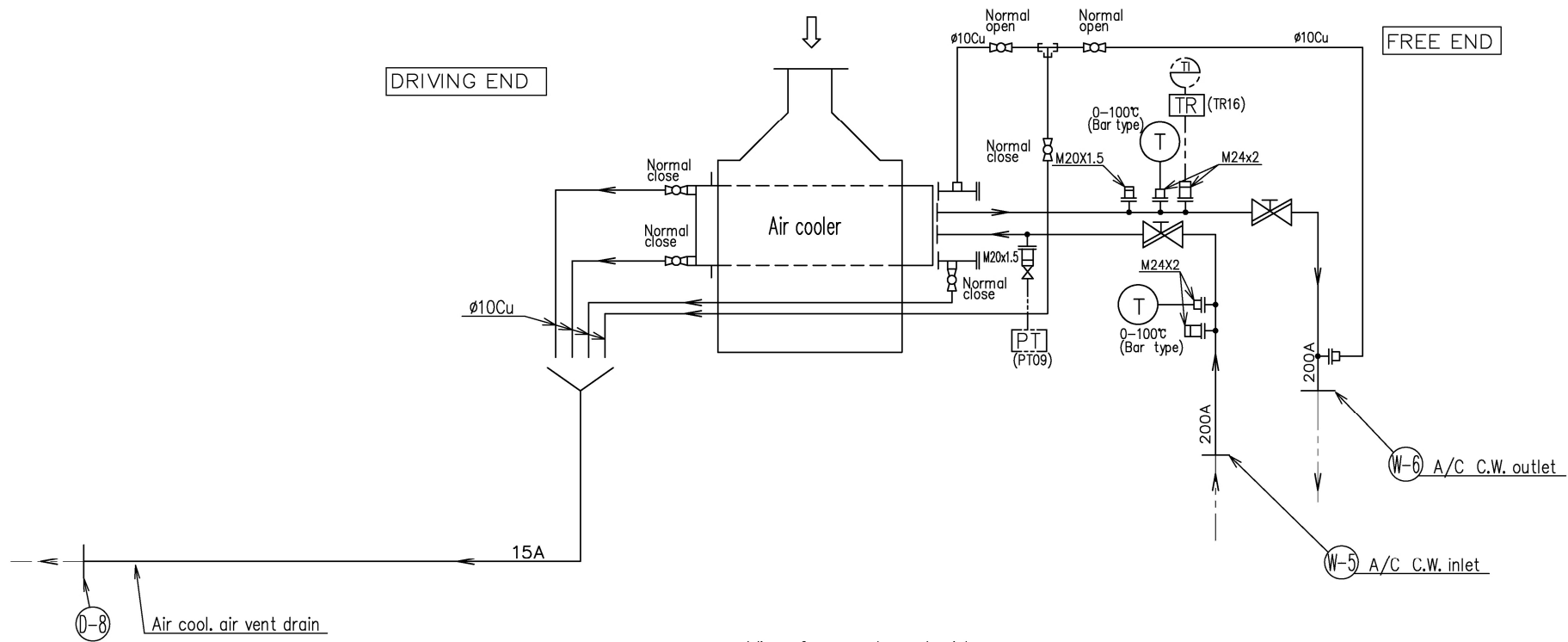

View from exhaust side

### 7UEC50LSH-Eco

Piping diagram of  
air cooler cooling water

空気冷却器冷却水管線図



FREE END

DRIVING END

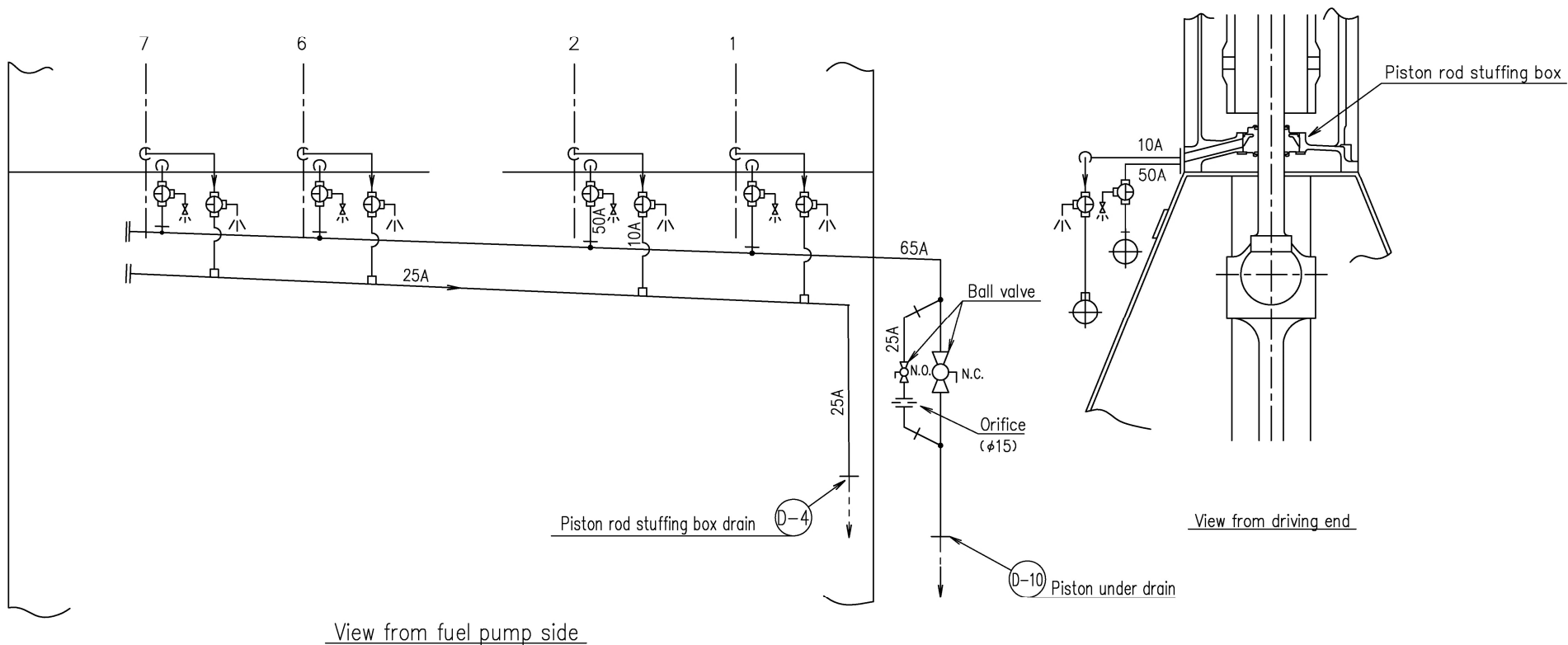

### 7UEC50LSH-Eco

Piping diagram of piston rod stuffing box drain

ピストン棒パッキン箱ドレン管線図



DRIVING END

FREE END

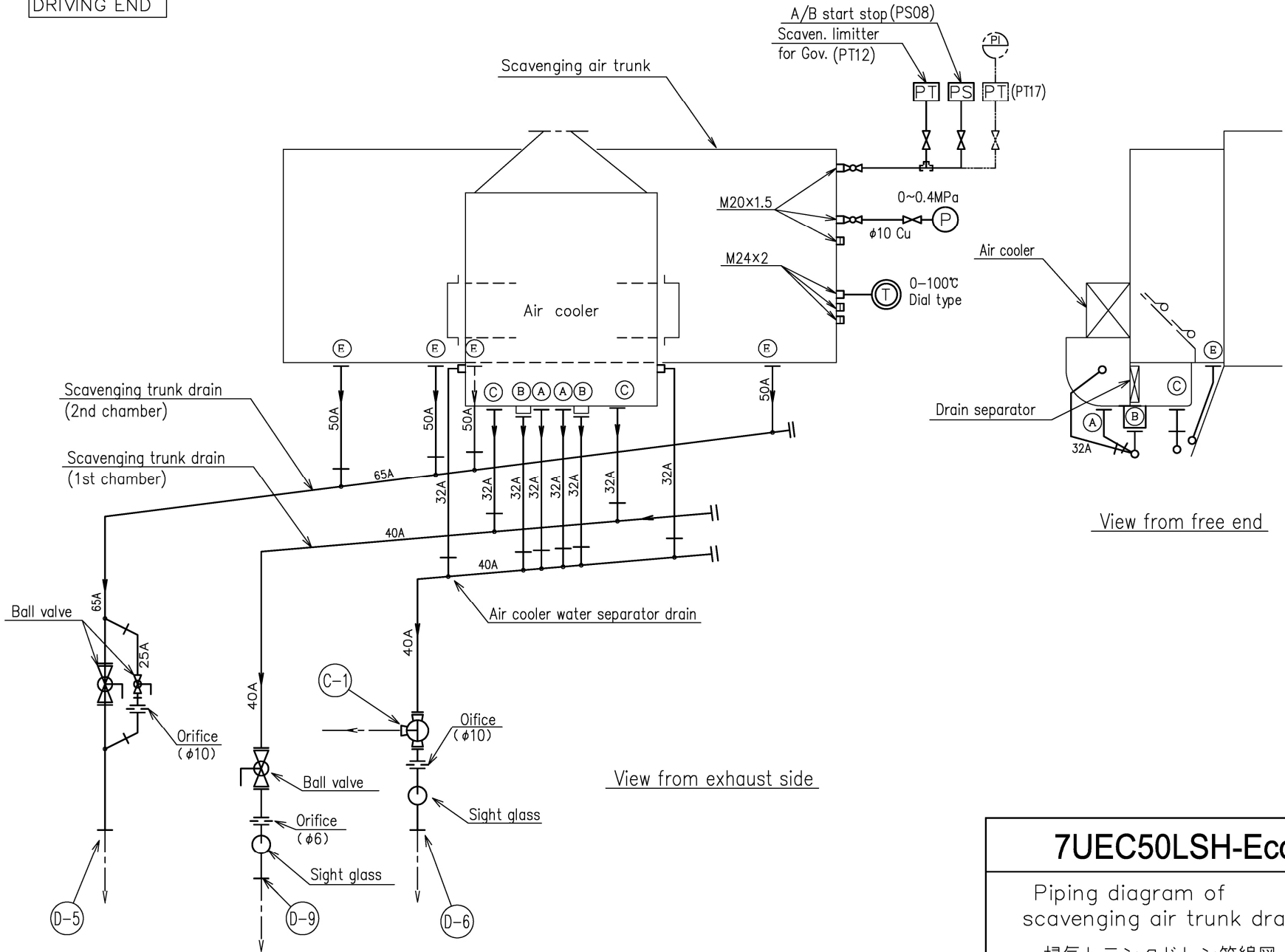

**7UEC50LSH-Eco**

Piping diagram of scavenging air trunk drain

掃気トランクドレン管線図

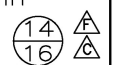

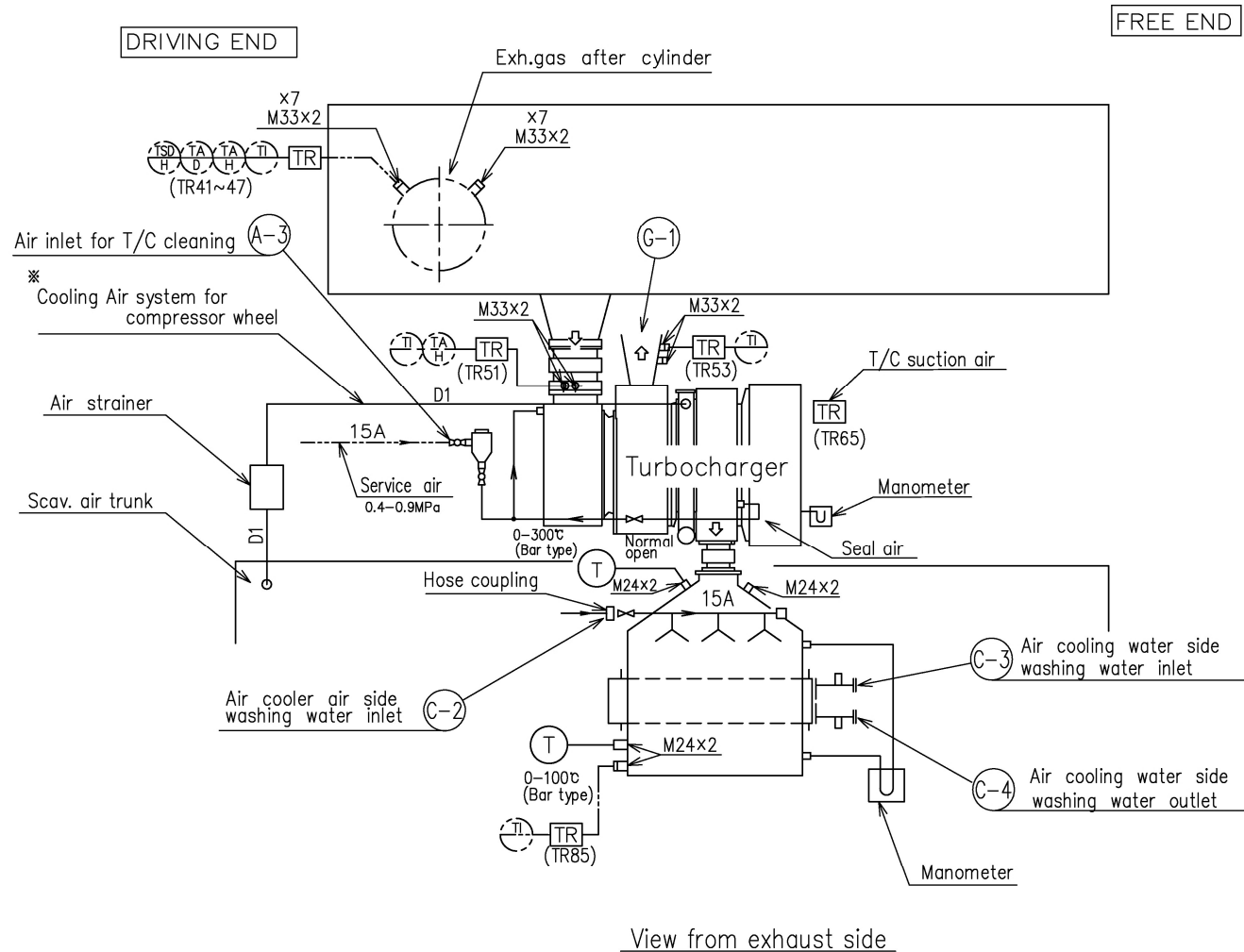

View from exhaust side

Turbocharger type	Pipe size
	D1
MET53MBx1	40A
MET60MBx1	40A

※ クーリングエアシステムは、機関の仕様により必要となる場合があります。お問い合わせください。

Depending on the engine specification, cooling air system may be required.

### 7UEC50LSH-Eco

Piping diagram of turbocharger and air cooler washing water and exhaust gas system

過給機空気冷却器洗浄水管及び排気ガス線図



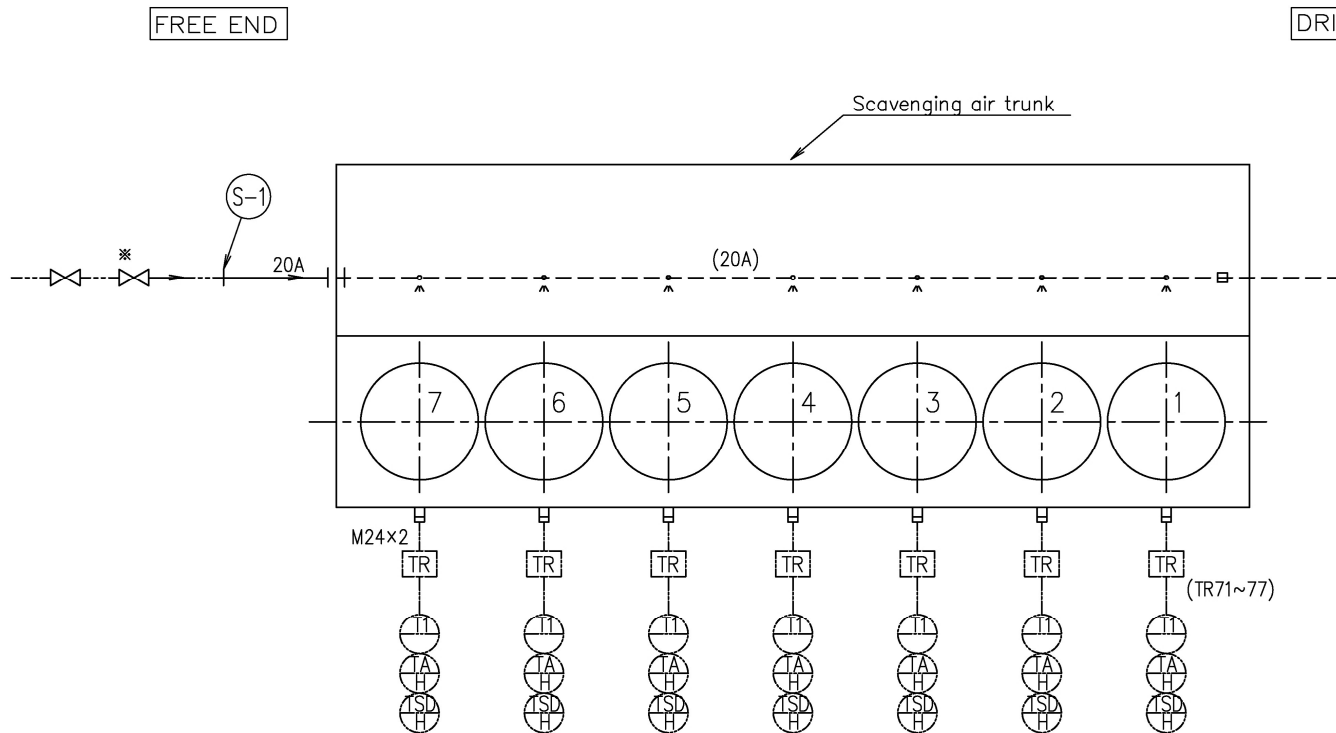

※ Supplied by shipyard.  
造船所殿所掌

**7UEC50LSH-Eco**

Piping diagram of  
fire extinguishing

掃気室火災消火装置管線図

